



## Installation & Operation Manual

### Full Inverter Swimming Pool Heat Pump





# Contents

1. Safety Consideration
2. Delivery
3. Specification
4. Dimension
5. Installation
6. Electric wiring
7. Operation
8. WiFi connection
9. Error codes
10. Exploded view
11. Operation logic
12. Maintenance
13. Winter Use

**1.Regulation (EU) n° 517/2014 of 16/04/14 on fluorinated greenhouse gases and repealing Regulation (EC) n° 842/2006**

**Leak checks**

1. Operators of equipment that contains fluorinated greenhouses gases in quantities of 5 tons of CO<sub>2</sub>, equivalent or more and not contained in foams shall ensure that the equipment is checked for leaks.

2. For equipment that contains fluorinated greenhouse gases in quantities of 5 tons of CO<sub>2</sub> equivalent or more, but of less than 50 tons of CO<sub>2</sub> equivalent: at least every 12 months.

**Picture of the equivalence CO<sub>2</sub>**

1. Load in kg and Tons amounting CO<sub>2</sub>.

**Load and Tons amounting CO<sub>2</sub>**

**Frequency of test**

From 7 at 75 kg load = from 5 at 50 Tons

Each year

**Concerning the Gas R32, 7.40kg amounting at 5 tons of CO<sub>2</sub>, commitment to check each year.**

**Training and certification**

1. The operator of the relevant application shall ensure that the relevant personnel have obtained the necessary certification, which implies appropriate knowledge of the applicable regulations and standards as well as the necessary competence in emission prevention and recovery of fluorinated greenhouse gases and handling safety the relevant type and size of equipment.

**Record keeping**

1. Operators of equipment which is required to be checked for leaks, shall establish and maintain records for each piece of such equipment

specifying the following information:

- a) The quantity and type of fluorinated greenhouse gases installed;
- b) The quantities of fluorinated greenhouse gases added during installation, maintenance or servicing or due to leakage;
- c) Whether the quantities of installed fluoridate greenhouse gases have been recycled or reclaimed, including the name and address of the recycling or reclamation facility and, where applicable, the certificate number;
- d) The quantity of fluoridate greenhouse gases recovered
- e) The identity of the undertaking which installed, serviced, maintained and where applicable repaired or decommissioned the equipment, including, where applicable, the number of its certificate;
- e) The dates and results of the checks carried out;
- f) If the equipment was decommissioned, the measures taken to recover and dispose of the fluoridate greenhouse gases.

**2. The operator shall keep the records for at least five years, undertakings carrying out the activities for operators shall keep copies of the records for at least five years**

## 1. SAFETY CONSIDERATION

Please read this manual carefully before proceeding with the installation or operation our pool heat pumps. This manual contains all necessary information for installation and operation and error codes. Installers must read the manual and follow the implementation and maintenance instructions carefully.

The installation should be done by the professional technicians, to prevent leaking, electric shock or fire. The ground wire must be connected for safety.

**WARNING:** Please drain water out from the heat pump unit if heat pump stopped to use in cold weather, otherwise it would be damaged by water freezing inside titanium exchanger, if ambient temperature dropped to below 0°C, which should be out of warranty by any improper use.

**WARNING:** It must be cut off the power supply before opening or repairing the heat pump by qualified technician, otherwise ,it is high risk to cause any body injured.

**WARNING:** Keep the display controller in a dry place, or close the insulating cover to protect the display controller from moisture damage.

### CAUTION :

- a. When installing the heat pump in a small room, make sure it is well ventilated.
- b. Do not put fingers or objects into the air inlet, because the rotating fan may cause serious injury.
- c. If you smell anything burning, turn off the manual power switch immediately, stop operation and contact the after-sale service department. Continued abnormal operation may cause electric shock fire.
- d. When the unit needs to be removed or re-installed, it must be carried out by qualified technicians. If the installation is not correct, it may cause unit operation failure, electric shock, fire, hurt, leaking, etc.
- e. Do no install the unit near flammable sources, as any leakages could cause a fire.
- f. Make sure the base on which the unit is installed is strong enough to support it.
- g. It is necessary to install a proper circuit breaker to prevent electric shock or fire.
- h. When cleaning the unit, it must be stopped operation, switch off and disconnect the power .



## 2. DELIVERY

### 2.1 Delivery of the unit



For the transportation, the heat pumps are fixed on the pallet and covered with a cardboard box. To protect from any damage, the heat pump must be transferred in its package. It is the responsibility of the addressee to notify of any damage incurred during delivery within 48 hours. No responsibility can be taken once the unit has been signed for.

### 2.2 Stock advice



- \* The warehouse should be bright, spacious, open, well ventilated, have ventilation equipment and no fire source.
- \* Heat pumps must be stored and transferred in vertical position in its original packaging. If it is not the case, it cannot be operated until a minimum period of 24H has passed before the unit can have the electrical power turned on.

### FORBIDDEN



### 2.3 Transfer to the final position

- \* During the unpacking of the product and the transfer from the pallet to the final place of installation, it is necessary to maintain the heat pump in a vertical position.
- \* Smoking and the use of flames are prohibited near R32machine.
- \* Water connection are not to be used as load bearing handles. The manufacturer would not take the responsibility in case of damage to the water pipes.

### 3. SPECIFICATION

Model No.	CHP-SPARK-7	CHP-SPARK-10	CHP-SPARK-13	CHP-SPARK-17	CHP-SPARK-21
* Heating Capacity at Air 26°C, Humidity 80%, Water 26°C in, 28°C out					
Heating Capacity (kW)	7.6~1.7	9.5~2.3	13~3.0	17~3.8	21~4.8
Power Input (kW)	1.12~0.11	1.40~0.15	1.91~0.19	2.5~0.24	3.09~0.30
COP	15.8~6.8	15.8~6.8	16~6.8	15.8~6.8	15.8~6.8
* Heating Capacity at Air 15°C, Humidity 70%, Water 26°C in, 28°C out					
Heating Capacity (kW)	6.1~1.4	7.6~1.9	9.8~2.3	13.5~3	16.5~3.8
Power Input (kW)	1.24~0.18	1.55~0.25	1.96~0.30	2.76~0.39	3.37~0.5
COP	7.6~4.9	7.6~4.9	7.6~5	7.6~4.9	7.6~4.9
* Cooling Capacity at Air 35°C, Water 29°C in, 27°C out					
Cooling Capacity (kW)	4.2~1.0	5.3~1.3	7.2~1.7	9.4~2.1	11.6~2.7
Power Input (kW)	1.11~0.15	1.4~0.19	1.89~0.25	2.47~0.31	3.05~0.4
EER	6.6~3.8	6.7~3.8	6.7~3.8	6.7~3.8	6.7~3.8
Power supply	220~240V~/50Hz				
Max Power Input (kW)	1.55	1.78	2.2	2.6	3.2
Max Current (A)	7.3	8.3	10.2	12	14.7
Water Flow Volume (m <sup>3</sup> /h)	2.5	3.5	4.5	5.5	6.5
Refrigerant	R32				
Heat Exchanger	Titanium heat exchanger in PVC				
Air Flow Direction	Horizontal				
Kind of defrost	Hot-gas defrosting				
Working temp. range	-15~43(Heating mode)				
	8~43(Cooling mode)				
	-15~43(Auto mode)				
Setting temp. range	8~40(Heating mode)				
	8~28(Cooling mode)				
	8~40(Auto mode)				
Water Proof Level	IPX4				
Noise level 1m dB(A)	39~49	40~52	42~53	43~55	45~56
Noise level 10m dB(A)	20~29	20~32	22~33	23~35	25~36
Net Weight	42kg	43kg	53kg	54kg	58kg
Gross Weight	53kg	54kg	64kg	65kg	69kg
Net Dimensions	864*349*592mm		925*364*642mm		
Package Dimensions	930*400*640mm		990*435*760mm		

Model No.	CHP-SPARK-30	CHP-SPARK-35
* Heating Capacity at Air 26°C, Humidity 80%, Water 26°C in, 28°C out		
Heating Capacity (kW)	28~6.8	35~8.8
Power Input (kW)	4.12~0.43	5.15~0.56
COP	15.8~6.8	15.8~6.8
* Heating Capacity at Air 15°C, Humidity 70%, Water 26°C in, 28°C out		
Heating Capacity (kW)	23~5.5	25.5~6.4
Power Input (kW)	4.7~0.72	5.2~0.84
COP	7.6~4.9	7.6~4.9
* Cooling Capacity at Air 35°C, Water 29°C in, 27°C out		
Cooling Capacity (kW)	14.9~3.8	19.3~4.9
Power Input (kW)	3.92~0.57	5.08~0.73
EER	6.7~3.8	6.7~3.8
Power supply	220~240V/1/50	
Max Power Input (kW)	4.45	4.76
Max Current (A)	20.4	30
Water Flow Volume (m <sup>3</sup> /h)	9	12
Refrigerant	R32	
Heat Exchanger	Titanium exchanger in PVC	
Air Flow Direction	Horizontal	
Kind of defrost	Hot-gas defrosting	
Working temp. range (°C)	-15~43(Heating mode)	
	8~43(Cooling mode)	
	-15~43(Auto mode)	
Setting temp. range	8~40(Heating mode)	
	8~28(Cooling mode)	
	8~40(Auto mode)	
Water Proof Level	IPX4	
Noise level 1m dB(A)	47~58	49~59
Noise level 10m dB(A)	27~38	29~39
Net Weight	88kg	98kg
Gross Weight	99kg	110kg
Net Dimensions	1084*399*737mm	
Package Dimensions	1146*460*862mm	



## 4. DIMENSION

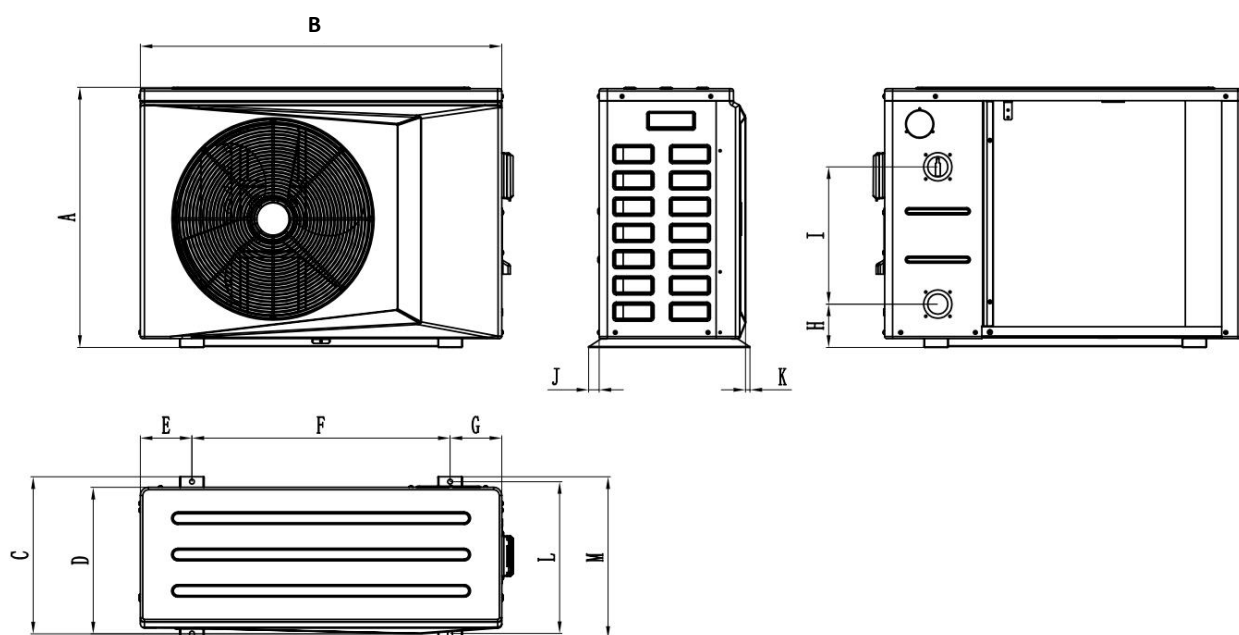

Model	A	B	C	D	E	F	G	H	I	J	K	L	M
CHP-SPARK-7 CHP-SPARK-10	591	836	379	335	98	640	98	107	290	26	11	355	379
CHP-SPARK-13 CHP-SPARK-17 CHP-SPARK-21	641	896	389	363	128	640	128	107	340	26	11	376	400
CHP-SPARK-30 CHP-SPARK-35	740.5	1056	428	401	173	710	173	101.5	440	27	17	421	445

## 5. INSTALLATION

### 5.1 Heat pump location

The unit will work properly in any desired location as long as the following three items are present:

1. Fresh air
2. Electricity
3. Swimming pool filters

The unit may be installed in virtually any outdoor location as long as the specified minimum distances to other objects are maintained. Please consult your installer for installation with an indoor pool. Installation in a windy location does not present any problem at all.

**ATTENTION:** Never install the unit in a closed room with a limited air volume in which the air expelled from the unit will be reused, or close to shrubbery that could block the air inlet. Such locations impair the continuous supply of fresh air, resulting in reduced efficiency and possibly preventing sufficient heat output.

**Note:** If automatic dosing equipment for chlorine and acidity (pH) is used, it is essential to protect the heat pump against excessively high chemical concentrations which may corrode the heat exchanger. For this reason, equipment of this sort must always be fitted in the piping on the downstream side of the heat pump, and it is recommended to install a check-valve to prevent reverse flow in the absence of water circulation. Damage to the heat pump caused by failure to observe this instruction is not covered by the warranty.

Please observe the space requirements indicated below for optimal operation and maintenance.

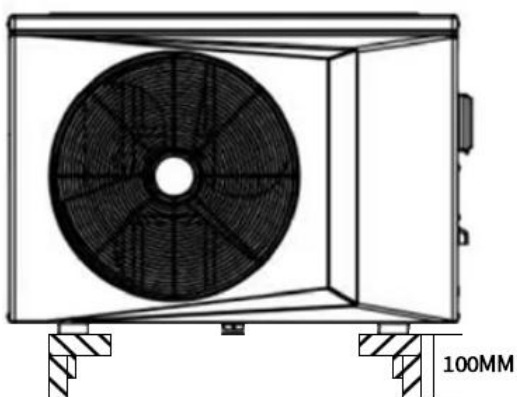
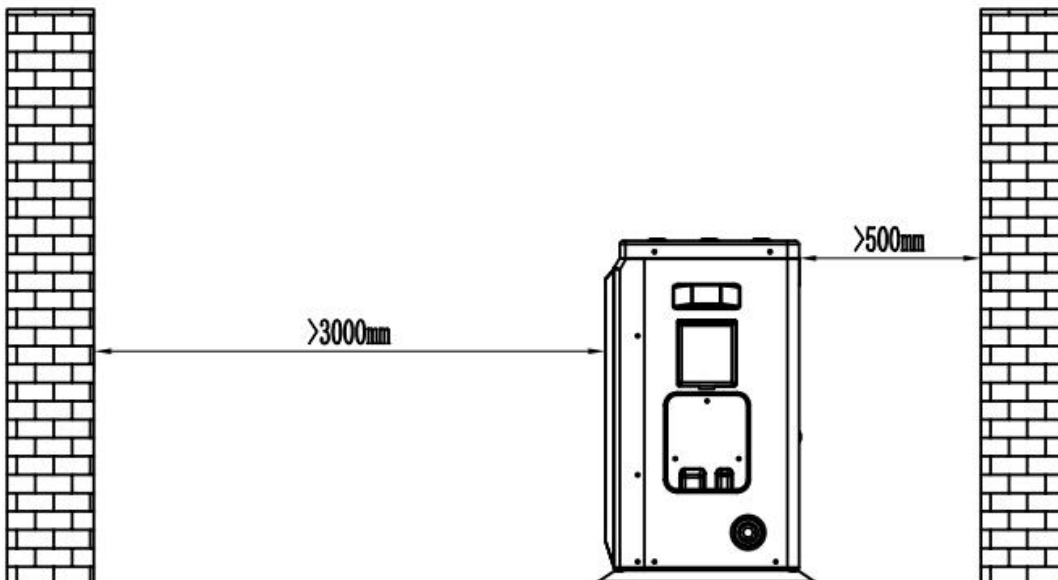
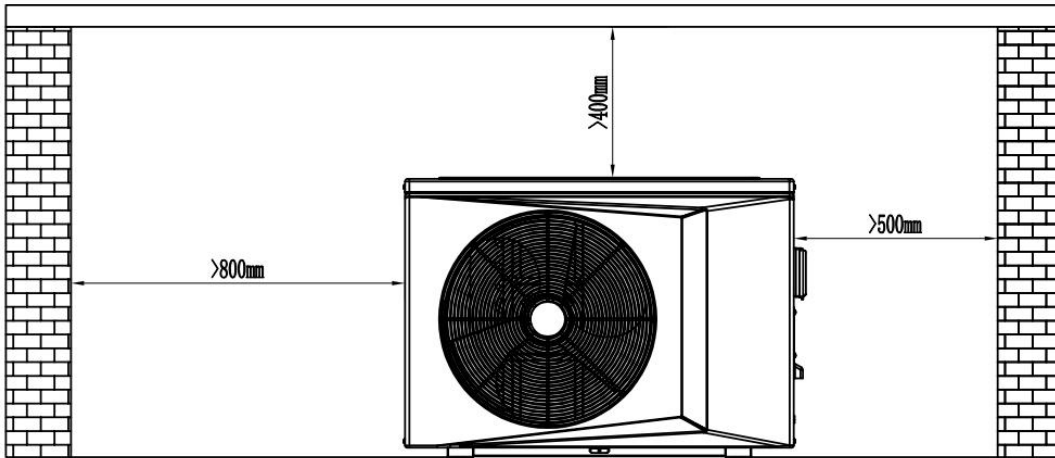

### 5.3 Pipeline installation diagram

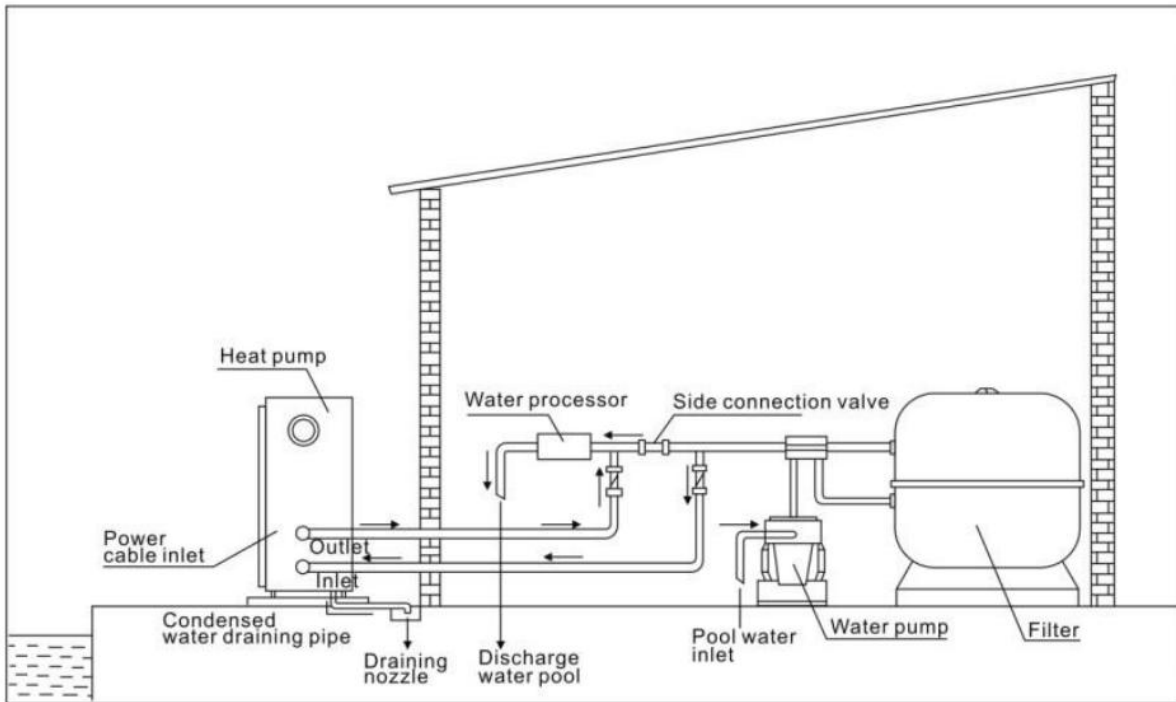

**ATTENTION:**

Please observe the following rules when installing the heat pump:

1. Any addition of chemicals must take place in the piping located downstream from the heat pump.
2. Always keep the heat pump upright. If the unit has been held at an angle, wait at least 24 hours before applying mains power to the heat pump.
3. In order to heat the water in the pool or (hot tub), the filtration water pump should be running, while it stops, heat pump should be stopped accordingly.

### 5.4 Installation check

**ATTENTION:**

- A. Avoid installations in locations containing mineral oil.
  - B. Avoid installation in locations where the air contains salt or other corrosive gases.
  - C. Avoid installation in locations with serious power supply voltage fluctuation.
  - D. Avoid installation in unstable places, such as a car or cabin.
  - E. Avoid installation near flammable items.
  - F. Avoid installation in locations with strong electromagnetic forces.
  - G. Avoid installation in locations with harsh environmental conditions.
- 
- a. Check the model, number, name etc, to avoid incorrect installation.
  - b. Make sure there is enough space for installation and maintenance.
  - c. Install in a dry well-ventilated place and make sure there are no obstructions around the air inlet and outlet.
  - d. Make sure the supporting base is strong enough and prepared to that shocks can be avoided.

- e. The power supply and diameter of the cables used must be in accordance with the electrical installation requirements.
- f. Electrical installation must comply with the relevant technical standards of electrical equipment, and electrical insulation work must be done.
- g. The unit must be put horizontally for at least eight hours before running.

### 5.5 The By-Pass Kit

The By-Pass Kit is the essential accessory for the installation of your heat pump, it is also a tool for the optimization of the heating of the water. The valves allows the optimum flow of water using a manometer to make sure the optimized running of the compressor, see paragraph 5.6 controls of the pressure.



### 5.6 Installation of pipe

- ① Prevent air, dust and other material from going into the water pipes.
- ② Fix the whole system before installing the water pipes.
- ③ Water inlet and outlet pipes should be protected by an insulation layer.
- ④ Make sure that there is a stable water flow, to prevent excessive throttling.
- ⑤ Do not handle, move or lift the unit by holding the water inlet and outlet pipe: use only the holes on the beam of the base.
- ⑥ When connecting the water inlet and outlet pipes, use two pipe wrenches to adjust the two parts of the pipes, and make sure the water inlet and outlet pipes do not twist.

## 6. Electrical Wiring

### 6.1 Electric connection

The power supply for the heat pump must come, preferably, from an exclusive circuit with regulatory protection components (30mA differential protection) and a magneto-thermal switch.

- The electrical installation must be carried out by a specialized professional (electrician) in accordance with the standards and regulations in force in the country of installation.

- The heat pump circuit must be connected to a safety earth circuit at the terminal block. - The cables must be

properly installed to prevent interference.

- The pump is intended for connection to a general power supply with earth connection. - Section of the cable; This section is indicative and should be checked and adapted according to the needs and conditions of use.

- The tolerance of acceptable voltage variation is +/- 10% during operation. The connections must be measured according to the power of the device and the state of installation

The unit should have a dedicated power supply in accordance with the recommended voltage.

### 6.2 Electrical Wiring Specification

The connections must be dimensioned according to the power of device and the state of installation.

Models	Circuit breaker	Electrical Wiring Specification	Maximum length of the wire			
			2.5mm <sup>2</sup>	4mm <sup>2</sup>	6mm <sup>2</sup>	10mm <sup>2</sup>
CHP-SPARK-7	16A	3*1.5 mm <sup>2</sup>	84m	135m	200m	335m
CHP-SPARK-10	16A	3*1.5 mm <sup>2</sup>	57m	90m	130m	225m
CHP-SPARK-13	16A	3*2.5 mm <sup>2</sup>	57m	90m	130m	225m
CHP-SPARK-17	16A	3*2.5 mm <sup>2</sup>	34m	54m	80m	135m
CHP-SPARK-21	20A	3*4 mm <sup>2</sup>	29m	45m	66m	110m
CHP-SPARK-30	40A	3*4 mm <sup>2</sup>	/	25m	38m	62m
CHP-SPARK-35	40A	3*6mm <sup>2</sup>	/	/	22m	36m

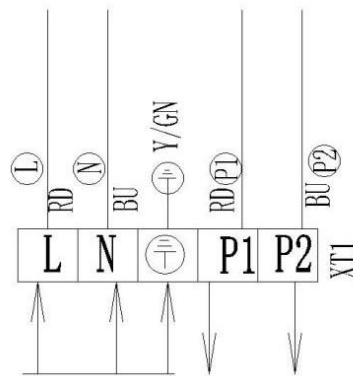

Power In To Pump, Maximum : 250W

AC:220V~240V / 50 Hz AC: 220V~240V/ 50 Hz

### 6.3 Circulation pump connection

The heat pump only provides a signal for the circulation pump, A separate A.C. Contactor is required to connect circulation pump.

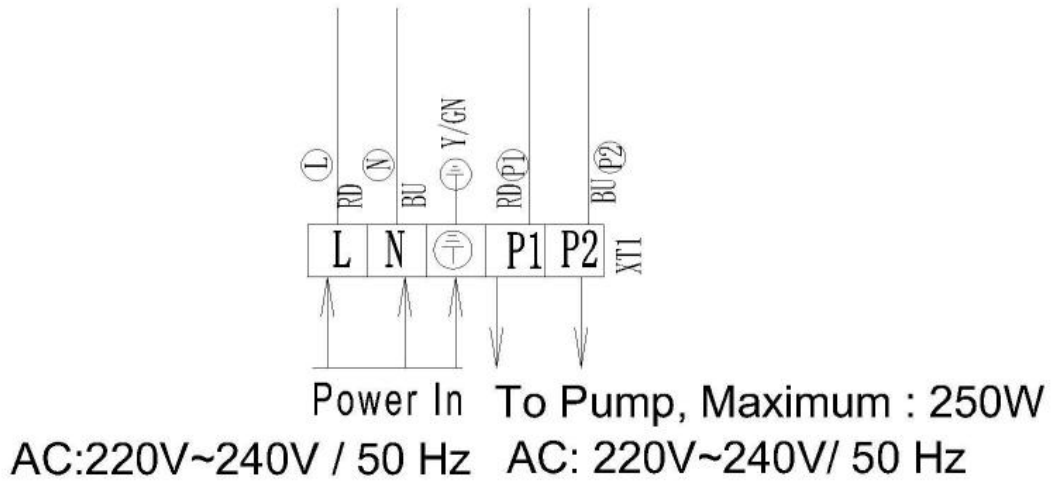

**NOTE:**

If the pump power less than 250w, please connect the pump as this drawing.

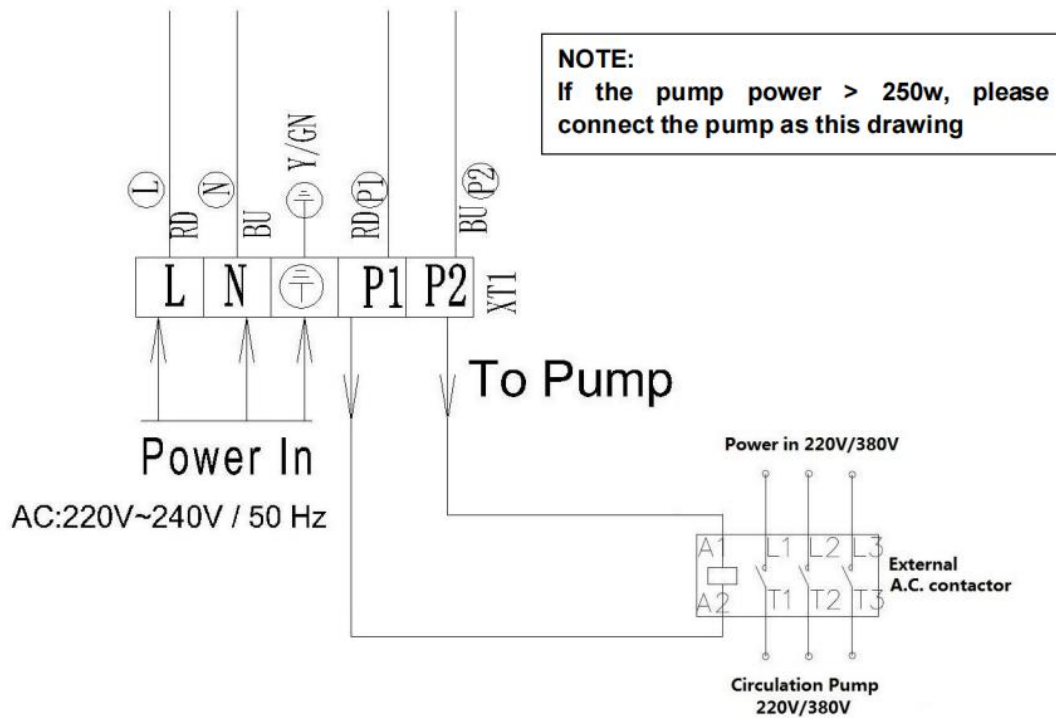

**6.4 Electric wiring diagram**

COMP : Compressor	GND : Ground
AMBT: Ambient temperature sensor	WFS: Water flow switch
LOW : Low pressure switch	HIGH : High pressure switch
COIL: Evaporator Coil Temperature Sensor	OWT/INWT: Inlet/ Outlet water temperature sensor

32190001000345

WIRE COLOR CODE	
BK	BLACK
PL	PURPLE
BU	BLUE
RD	RED
WH	WHITE
GN	GREEN
YL	YELLOW

  

Outlet Temp.	Outlet water temperature sensor
Inlet Temp.	Inlet water temperature sensor
Suc. Temp.	Suction temperature sensor
Exhaust Temp.	Exhaust temperature sensor
Amb. Temp.	Ambient temperature sensor
Coil Temp.2	Coil temperature sensor 2
Coil Temp.1	Coil temperature sensor 1
MF	Constant Current Motor Fan
4WV	4 way valve
HPS	High pressure switch
LPS	Low pressure switch
WFS	Water flow switch
COMP	Compressor
LED	LED Lamp
XT1	Terminal
EEV1	Electronic Expansion Valve
Abbreviation	Full name

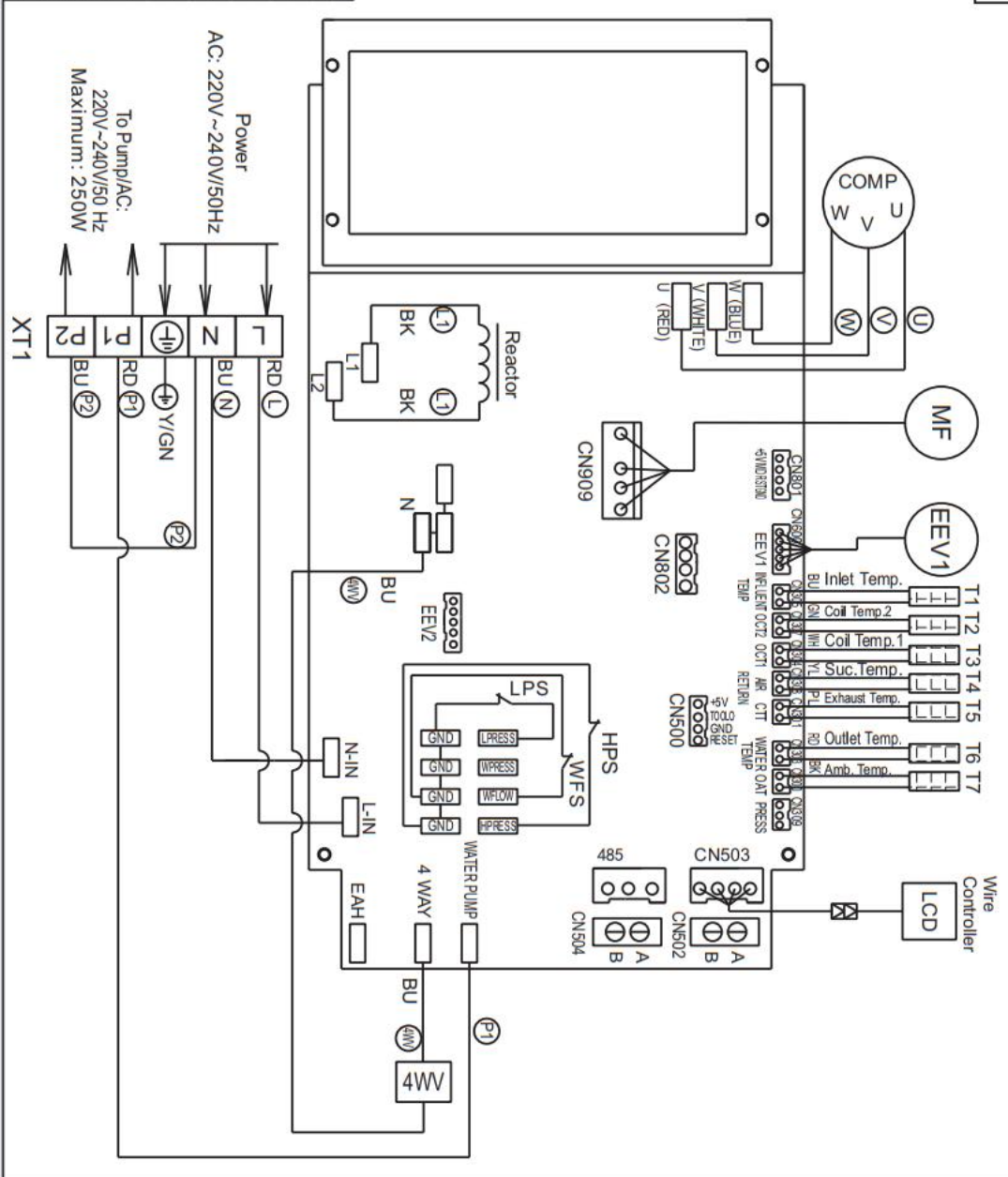

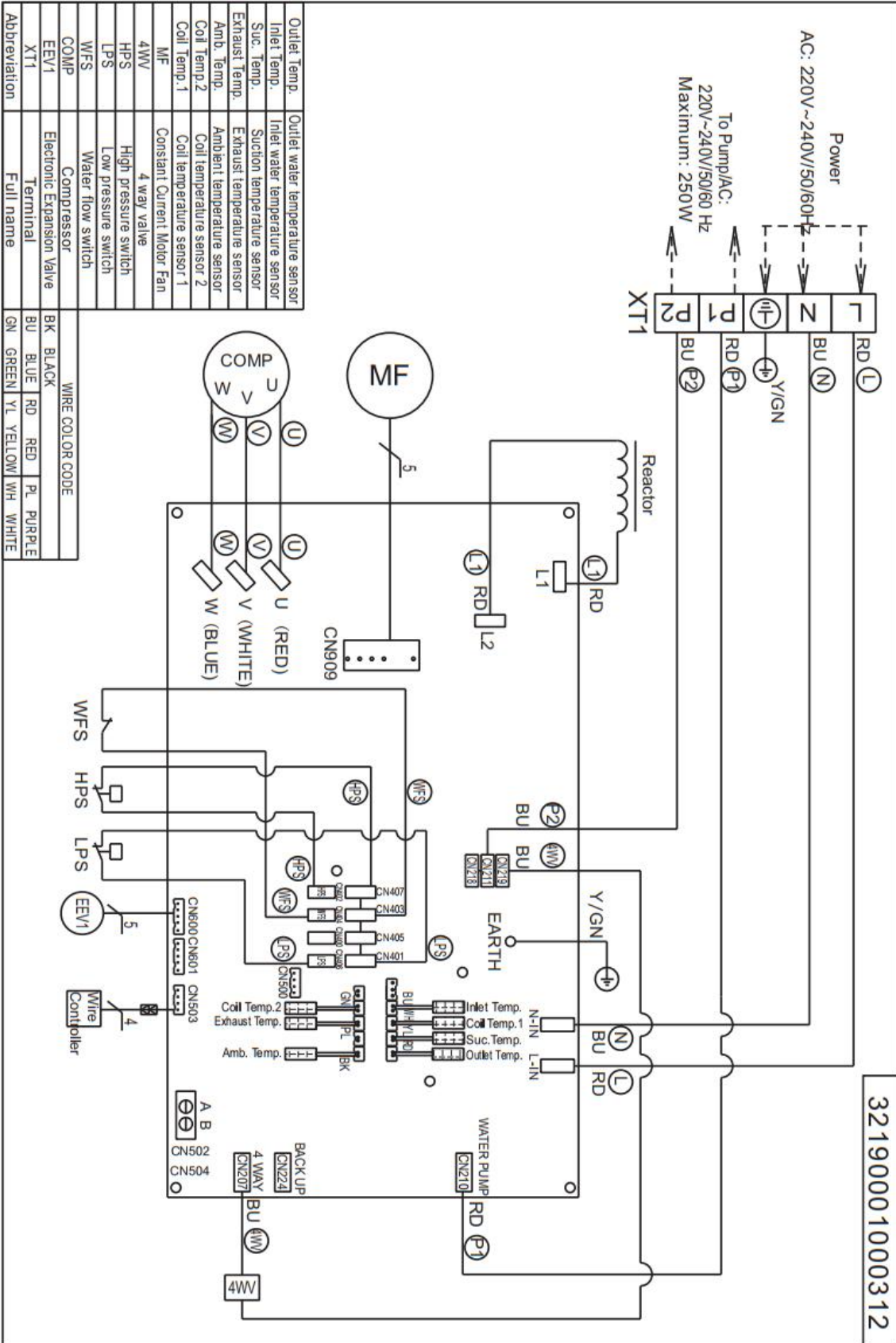



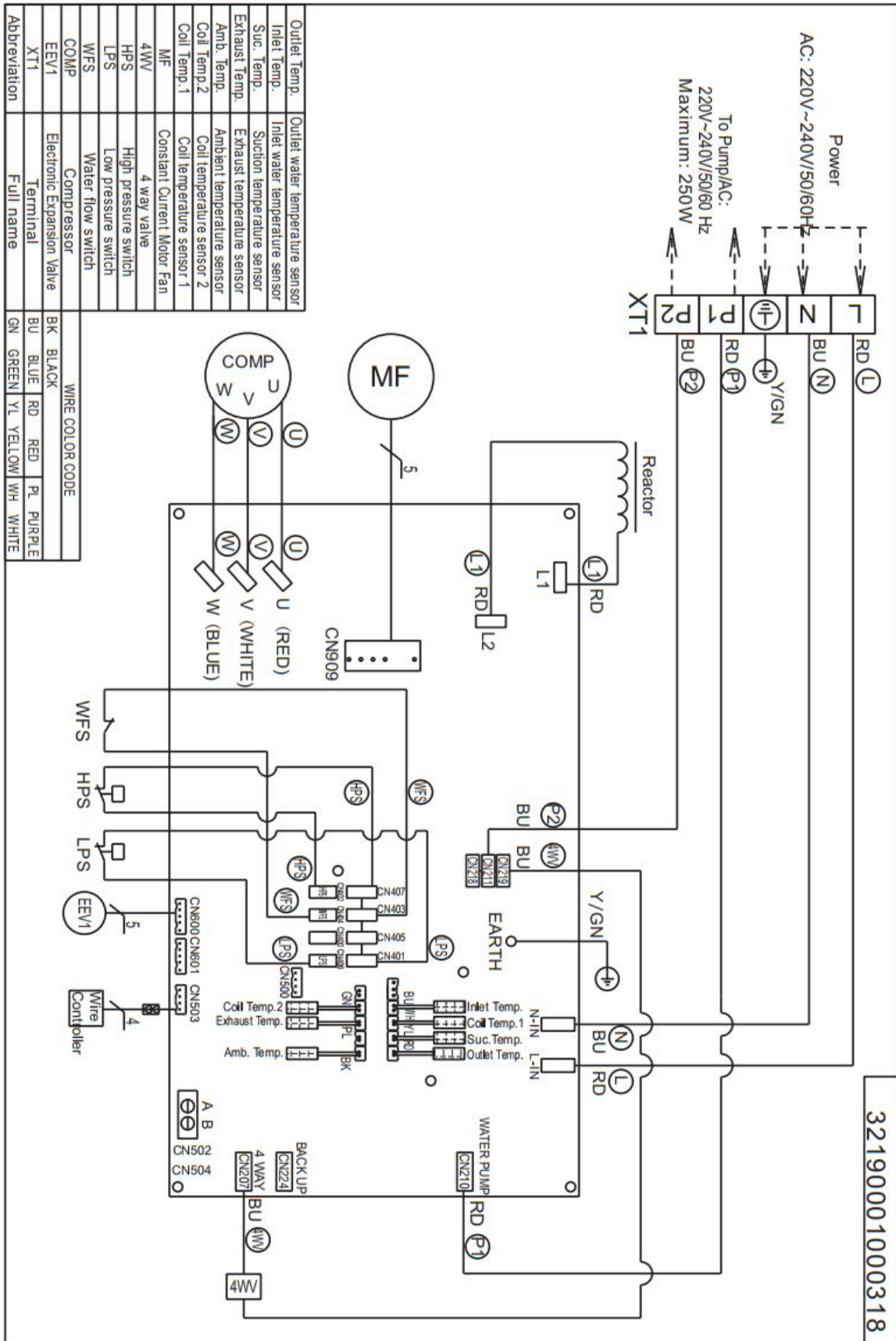

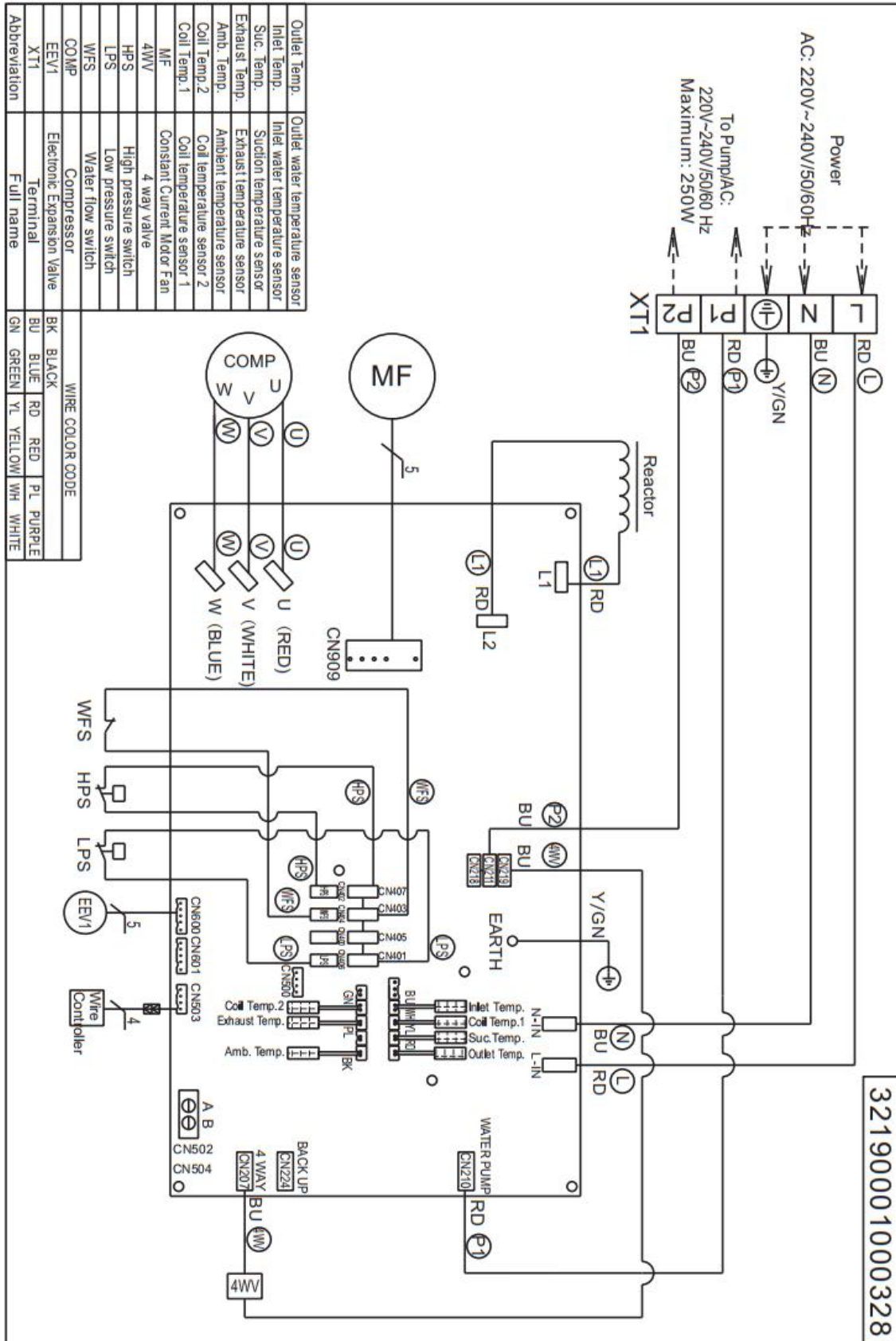

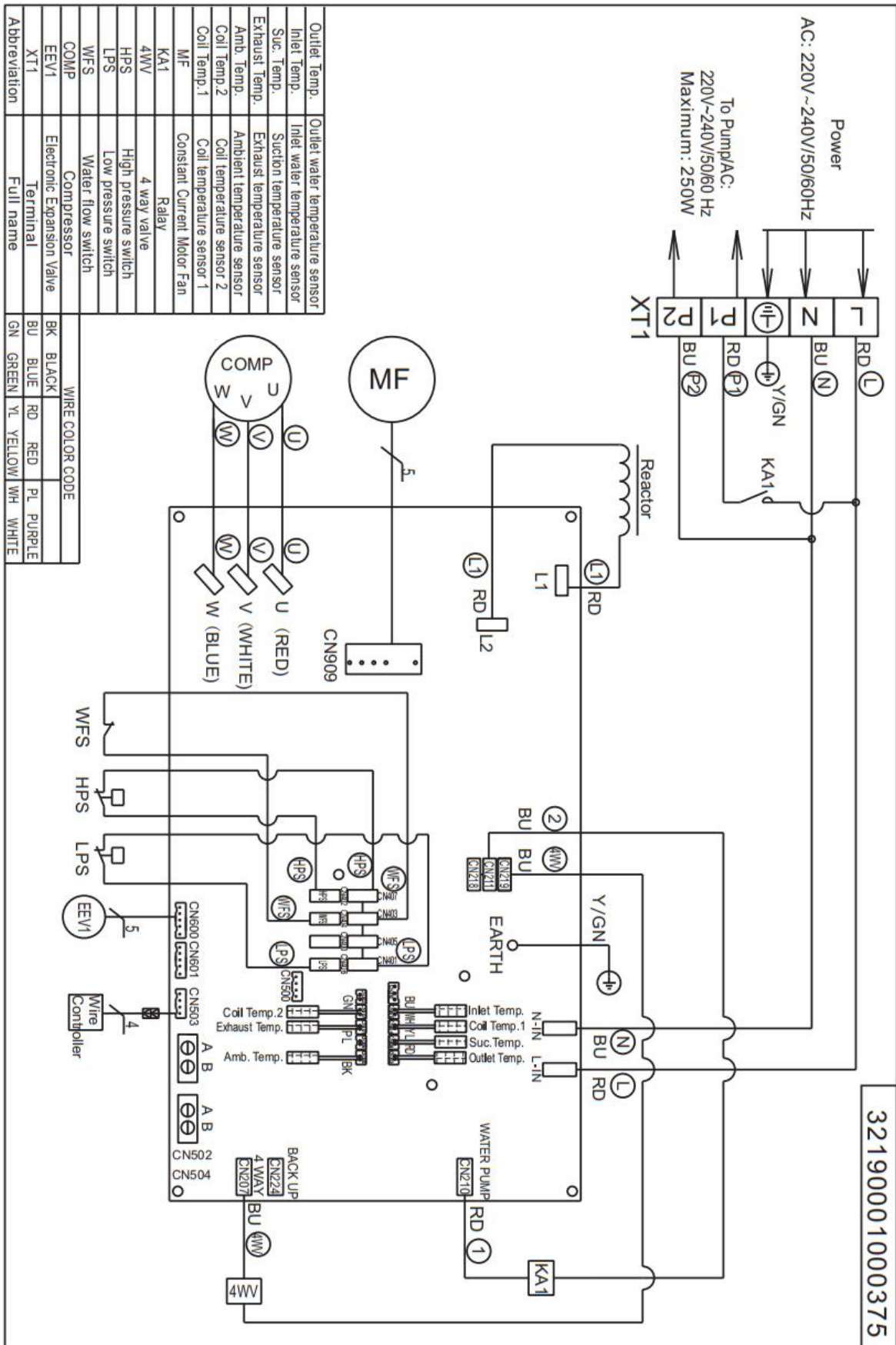

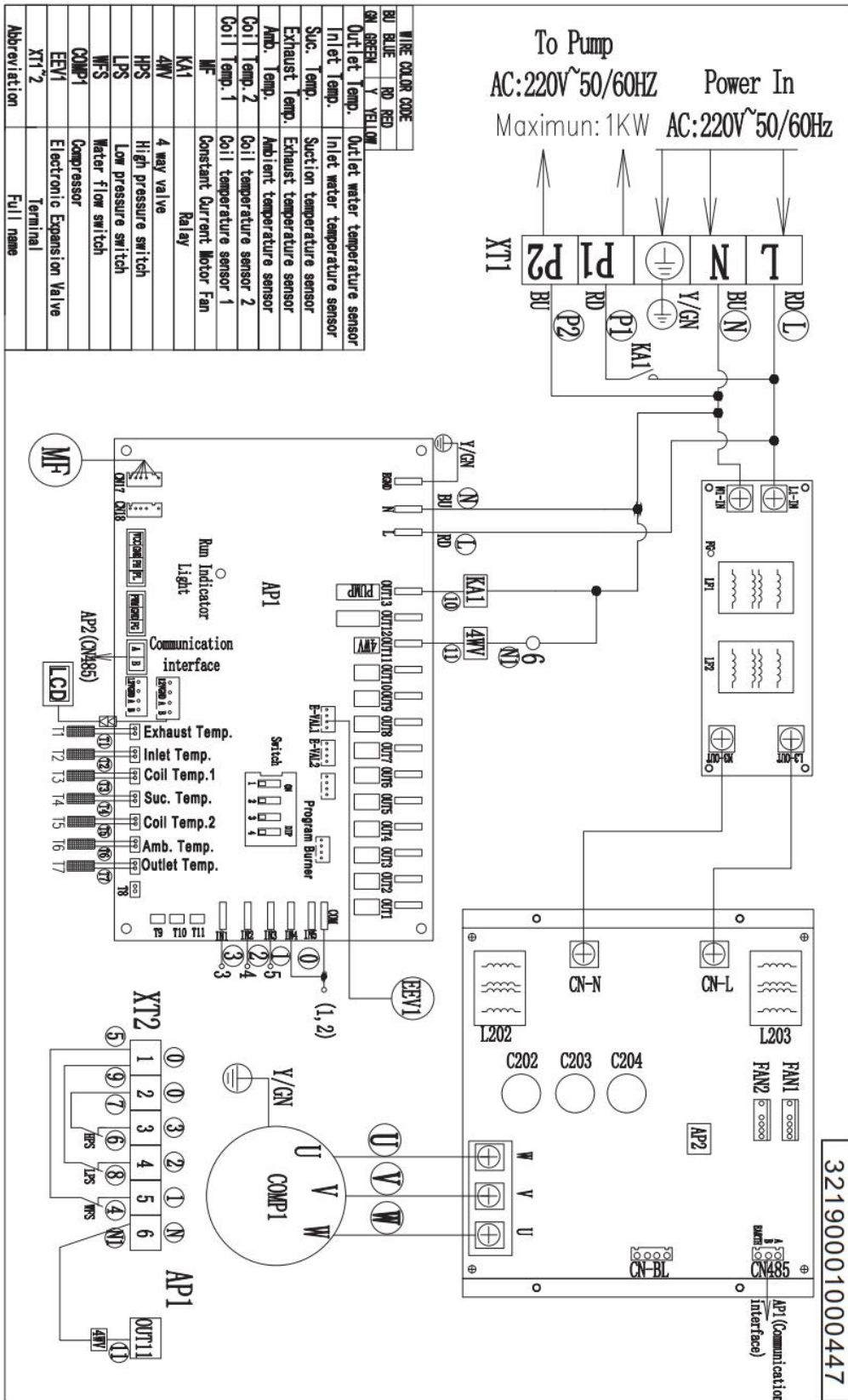



## 7. OPERATION

### 7.1 Initial operation

After all connections have been made and checked, carry out the following procedure:

1. **Switch on the filtration pump.** Check for leaks and verify that water is flowing to and from the swimming pool.
2. **Connect power** to the heat pump and press the On/Off button on the electronic control panel. The unit will start up after the time delay expires (see below).
3. After a few minutes, **check whether the air blowing out of the unit is cooler.**
4. When the filtration pump is turned off, the unit should also turn off automatically.
5. Allow the heat pump and the filtration pump to **run 24 hours a day until the desired water temperature is reached.**

Depending on the initial temperature of the water in the swimming pool and the air temperature, it may take several days to heat the water to the desired temperature.

**Water Flow Switch:** It is equipped with a flow switch for protecting the HP unit running with adequate water flow rate. It will turn on when the filtration pump runs and shut it off when the pump shuts off.

**Time delay** - The heat pump has a built-in 3-minute start-up delay to protect the circuitry and avoid excessive electrical contactor wear. The unit will restart automatically after this time delay expires. Even a brief power interruption will trigger this time delay and prevent the unit from restarting immediately. Additional power interruptions during this delay period do not affect the 3-minute duration of the delay.

**Condensation** - The air drawn into the heat pump is cooled by the operation of the heat pump for heating the pool water, which may cause condensation on the fins of the evaporator.

**Note:** The amount of condensation may be as much as several liters per hour at high humidity. The condensate will drain from the bottom of the heat pump. This is sometimes mistakenly regarded as a water leak.

### 7.2 Wire controller (Buttons and Icons)

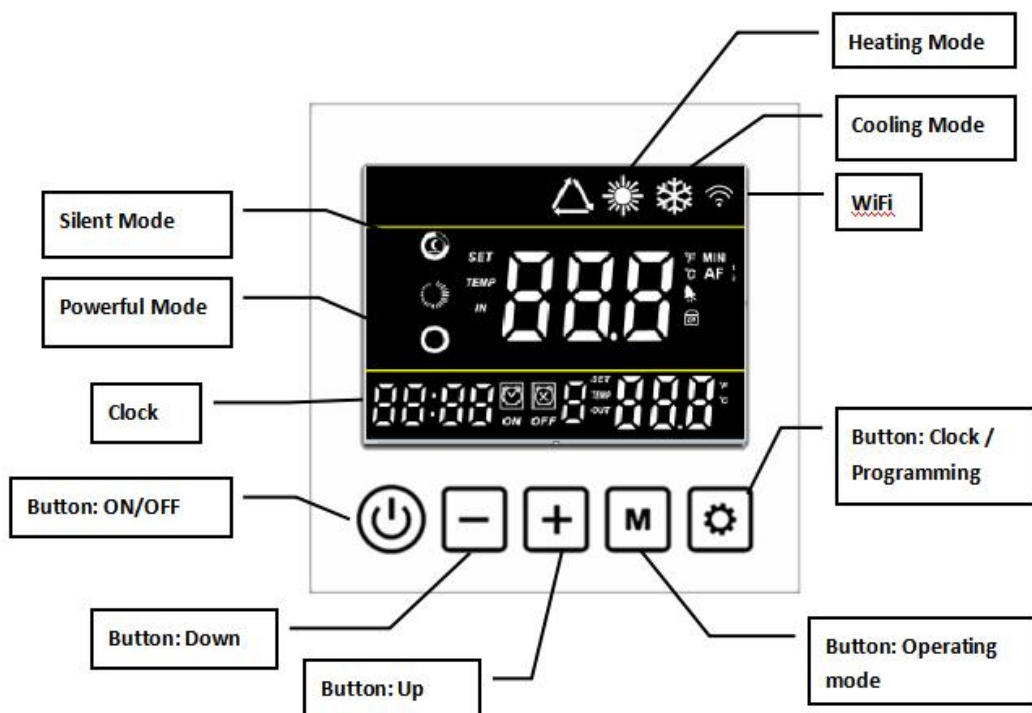

### 7.3 Start up & Locking

 **Attention:** Before you start the machine, please make sure the filtration pump is running and there is water flow goes through the heat pump.

Hold the button  for 3 seconds to switch the heat pump ON or OFF.



On the main interface, hold  and  for 3 seconds to lock or unlock the controller.

When the controller is locked, the icon  appears.



### 7.4 Mode Selected



Hold the button **M** for 3 seconds to change the below three operating functions each time:

☀ Heating function    ❄ Cooling function    ▲ Auto function

Under Auto function, if the real situation is in Heating, it will show ▲ and ☀, if the real situation is in Cooling, it will show ▲ and ❄.

Press button **⚙** to change the below two running modes each time:

🌙 Silent mode: Choose this mode that the heat pump operates silently.

⦿ Powerful mode: Choose this mode that the heat pump operates powerfully.

### 7.5 Set the required temp.











On the main interface, press **+** or **-** to adjust the required water temp. Of your pool, then

press  to save the setting.  
 Or you can adjust the Parameters P01/P02 to set the required water temp.

### 7.6 Clock setting



Hold  and  for 3 seconds to enter Clock setting interface.

Clock display on left bottom flashes. Change the Hours using  or , press  to save the Hours, the Minute flashes, press  or  to adjust the Minute. Press  to save the data.

### 7.7 Timer setting



Hold the button  for 3 seconds to enter the setting of Timer ON & Timer Off groups.  
 Then use the same method to make the setting of Hour and Minute like Clock setting.

**Pay attention: There are 3 groups Timer for your every day setting.**





See above photo, the icon 'ON' will flash when setting the Timer ON. The icon 'OFF' will flash when setting the Timer OFF.

The last data is the Order No. of your current setting for Timer group. It will flash under Timer setting.

Press  to save the Timer setting and back to the main interface, it will show Numbers of Timer groups you have set on the main interface.

**Cancellation of Timer:** When the Timer On is same to Timer Off, the current Timer group has been canceled.



### 7.8 Definition of other icons

: Defrosting when it flashes

: WiFi connected. It will flash under WiFi connecting.









: It will flash when there is Error code or system protection.

### 7.9 Manual defrosting

Hold  and  for 5 seconds, and when the Piping temp. is below than Exit defrosting temp., the system can enter into Manual defrosting.







### 7.10 Parameters Setting

On the main interface, hold  for 3 seconds to enter Parameter setting. Press  and  to check the parameter from P01~P05, press  to select the parameter, then press  and  to adjust the data, then press  again to save the data. Press  to go back the main interface.



Code	Description	Range	Default
P01	Desired water temp. in Heating mode	8°C~40°C	27°C
P02	Desired water temp. in Cooling mode	8°C~28°C	27°C
P03	Desired water temp. in Auto mode	8°C~40°C	27°C
P04	Adjustment of water temp. difference before restart	1°C~18°C	1°C
P05	Water pump stop or nonstop once the temperature is reached the setting temperature.	0=Non stop, 1=Stop	1





### 7.11 Running Parameter checking

On the main interface, hold  for 3 seconds to enter Parameter checking. Press  and  to check the parameter from A01~A14. Press  to go back the main interface.











Code	Description	Scope
A01	Inlet water temp.	°C
A02	Outlet water temp.	°C
A03	Ambient temp.	°C
A04	Exhaust temp.	°C
A05	Gas return temp.	°C
A06	Outer piping temp.	°C
A07	Inner piping temp.	°C
A08	EEV aperture	
A09	Compressor current	A
A10	Radiator temp.	
A11	Voltage value	V
A12	Frequency	Hz
A13	Fan motor speed	r/min
A14	Fan motor speed	r/min

### 7.12 Restore the factory parameter setting

In the shutdown state and the main interface, press and hold the buttons of  +  and  +  for 3 seconds to reset the factory parameter setting.

### 7.13 System parameter system

Press and hold  +  on the main interface for 5 seconds to enter system parameter settings. Use  and  to query the parameters. Press  to confirm to enter

the system parameter setting, use  or  to adjust the value, press  again to confirm, press  to exit the parameters and return to the main interface.

System Code	System Parameter	Adjustable Range	Initial Value
P06	Exhaust over-high protection setting temperature	80°C-125°C	120°C
P07	Restore the set temperature when the exhaust gas is too high	50°C-100°C	95°C
P08	Compressor current protection	2A -50A	Reserved
P09	Inlet water temperature compensation	-5°C to 15°C	0°C
P10	Reserved	-	-
P11	Defrost cycle	20Min to 90Min	40Min
P12	Defrost entry temperature	-15°C-1°C	-6°C
P13	Defrost time	5Min-20Mini	11Min
P14	Defrost exit temperature	1°C- 40°C	16°C
P15	Defrost temperature difference of environment and coil	0°C-15°C	6°C
P16	Ambient temperature for defrosting	0°C-20°C	6°C
P17	EEV action cycle	20s-90s	30s
P18	Heating target superheat	-5°C-10°C	1°C
P19	EEV regulated exhaust temperature	70°C-125°C	88°C
P20	EEV opening for defrosting	20-450	
P21	EEV minimum opening	5-150	80
P22	EEV mode Selection	0 Auto/1 Manual	0
P23	EEV manual steps	20-450	300
P24	Cooling target superheat	-5°C-10°C	1°C
P25	Reserved	-	-
P26	Reserved	-	-
P27	EEV working mode in cooling	0= Ambient 1= Superheat	1
P28	Mode switching time	3-30min	10min

## 8. WiFi connection

### 8.1 Download the APP in your smart phone:



### 8.2 WiFi connection

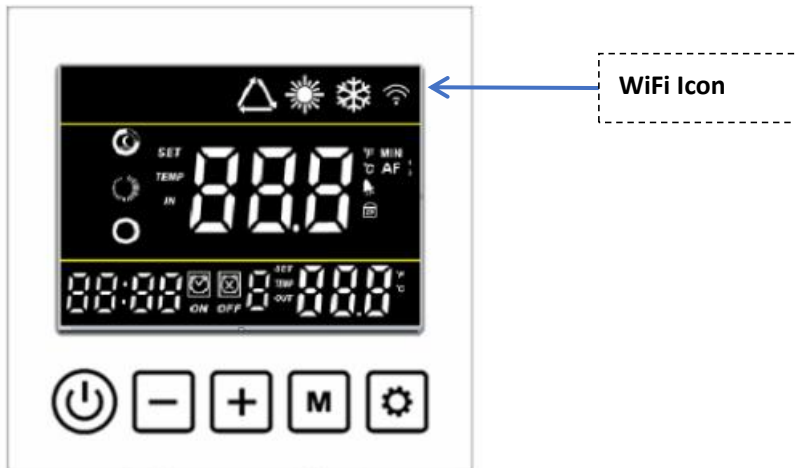

#### Step 1: WiFi connection:

Press and simultaneously hold 2 keys  +  for 5S to connect the WiFi .

The WiFi icon will flash then enter into WiFi connection.

If WiFi is connected successfully, the WiFi icon will be lighted over 5S, otherwise, WiFi connection is failure, then please reconnect as below:

#### Method 1: Restart the controller

**Method 2:** Press and simultaneously hold 2 keys  +  for 5S to re-set the WiFi module.

### 8.3 User registration

When using the "smart life" software for the first time, user registration is required.

Click the "Create New User" link to enter the registration interface.

If you already have an account, just click to login.

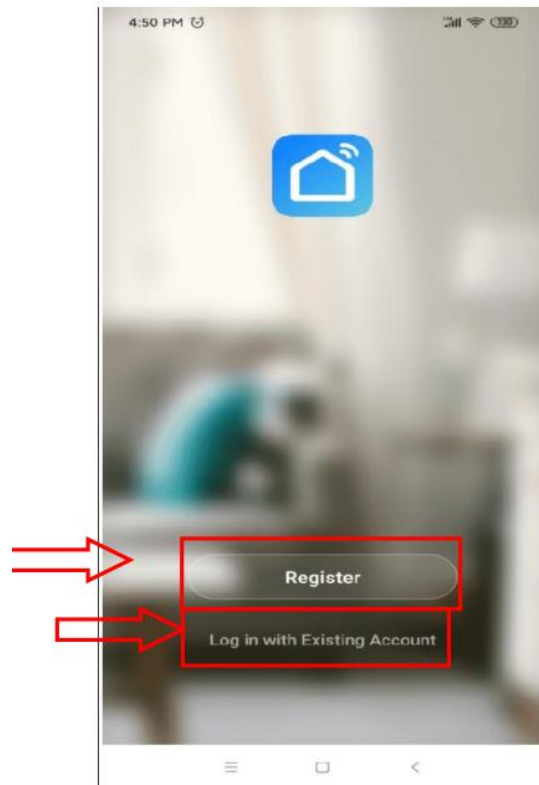

After entering the registration page, please follow the instruction on the page to register.

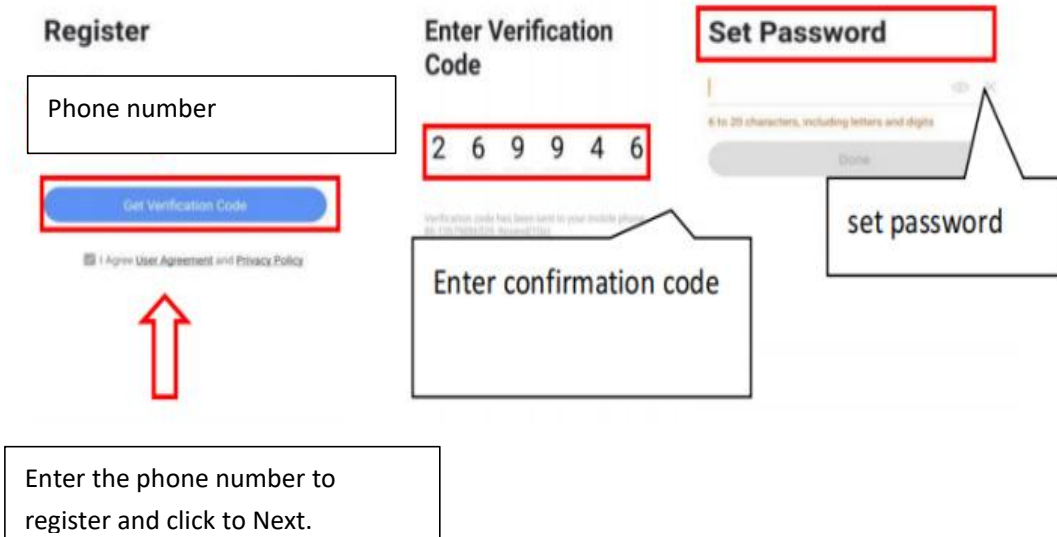

Enter the phone number to register and click to Next.

### User login

After successful registration, the software will jump to the login interface or directly log in successfully, enter the correct "user name" and "password" to log in.

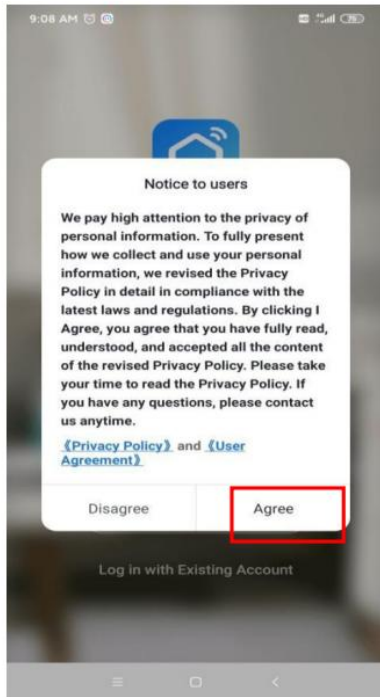

Need to select "Agree"

The phone needs to be connected to the network through the WIFI network

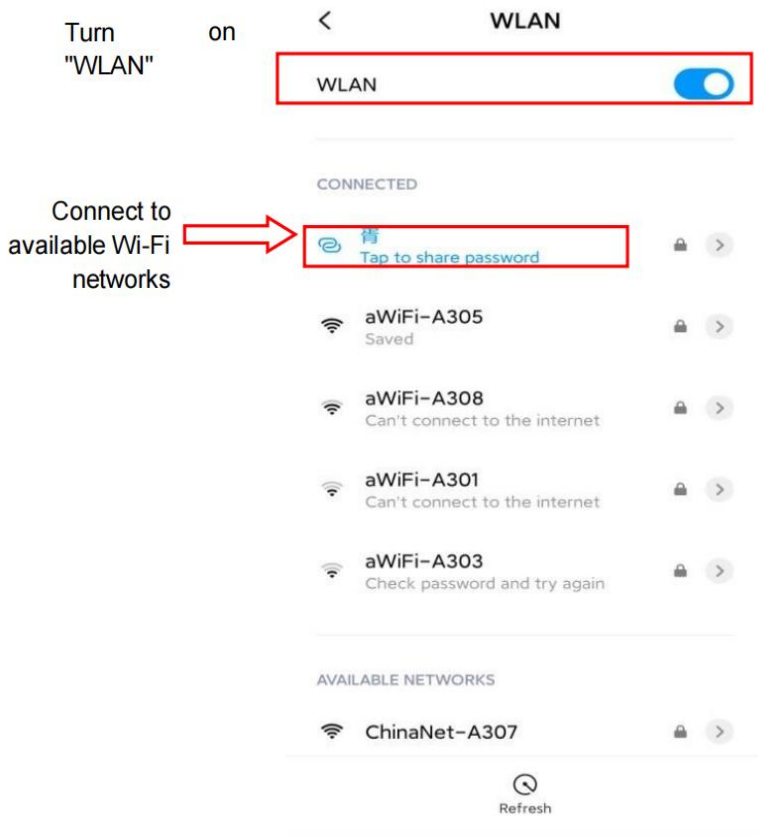

After users log in the APP, devices can be added.  
Device connect  
Click "+" or "Add Device" in the upper right corner to connect.

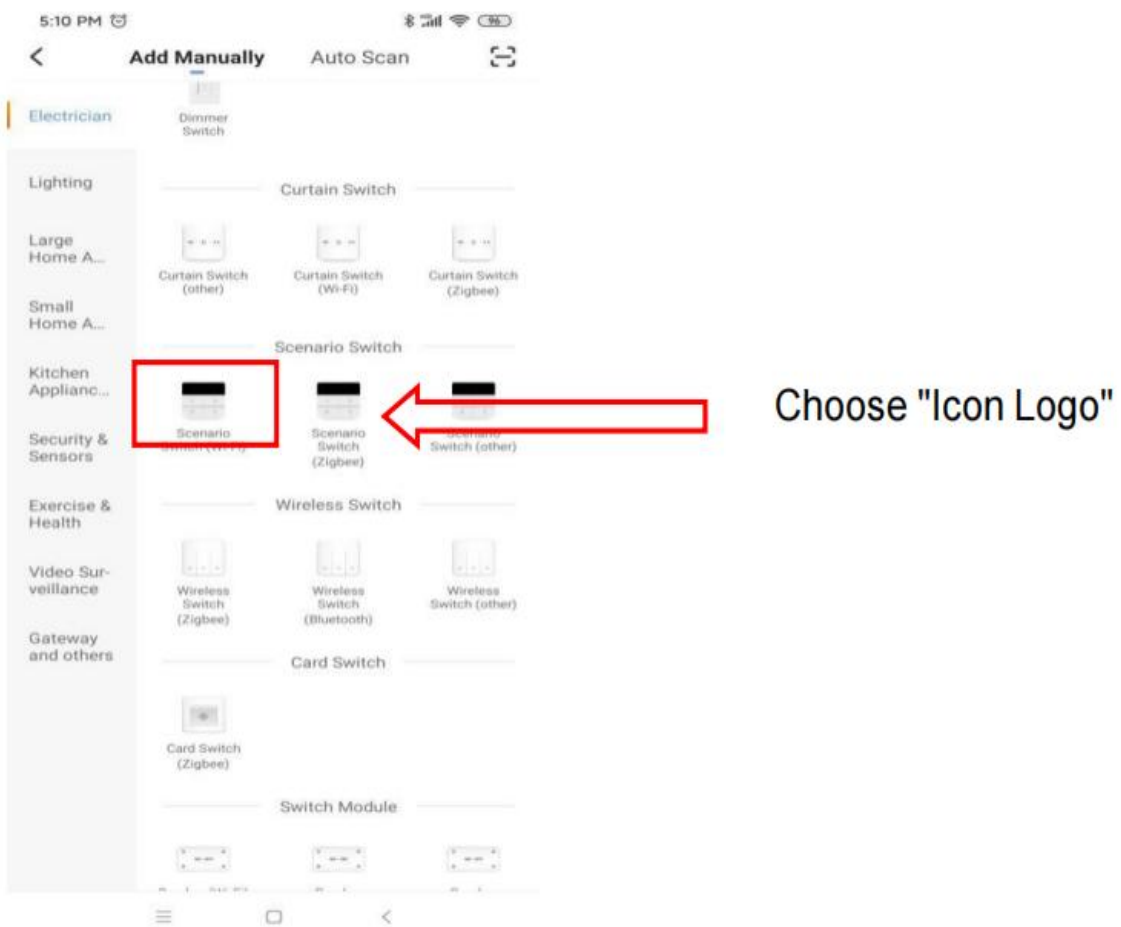
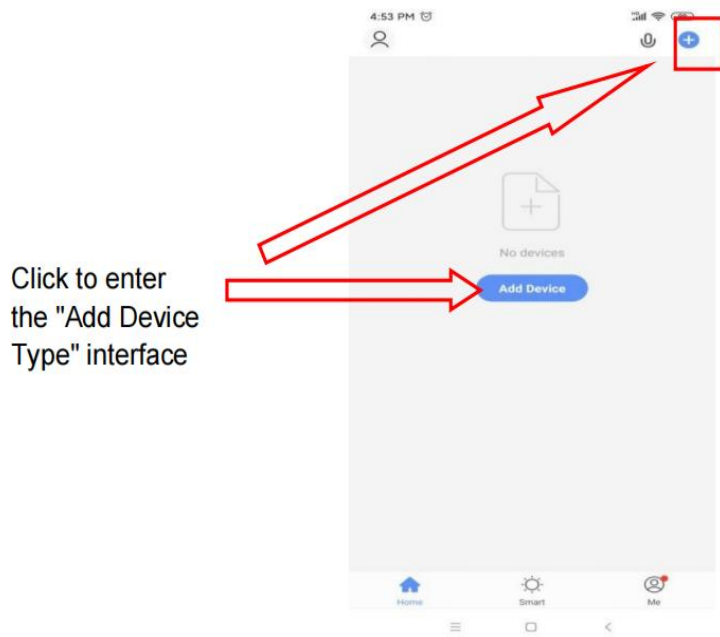

After completing the "Select Device Type", enter the "Add Device Interface", and the network



configuration methods are divided into "default mode (WI-FI fast connection)" and "compatibility mode (hotspot distribution network)"

Default mode (WI-FI fast connection):



**Device not responding**  
**Try "Switch Pairing Mode"**

- ① Check if the device has been reset and the indicator is blinking quickly.
- ② Check if it is 2.4 GHz Wi-Fi.
- ③ Verify the Wi-Fi password.



If the network distribution fails, the APP will display the page as shown in the figure, you can choose to re-add or view the help.

**Compatibility mode:**

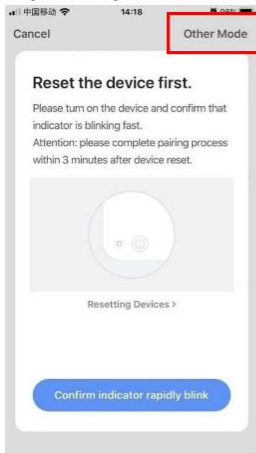

Select "Other Ways" in the Add Device

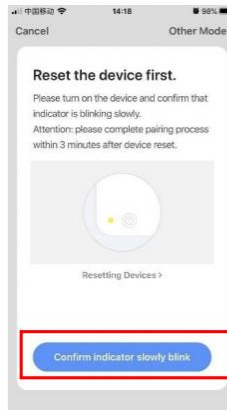
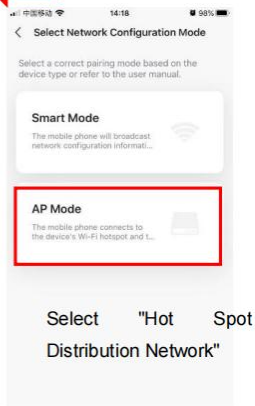

Press and hold the timing key +, down key +, power key simultaneously for 3 seconds to enter the "compatibility mode" distribution network.

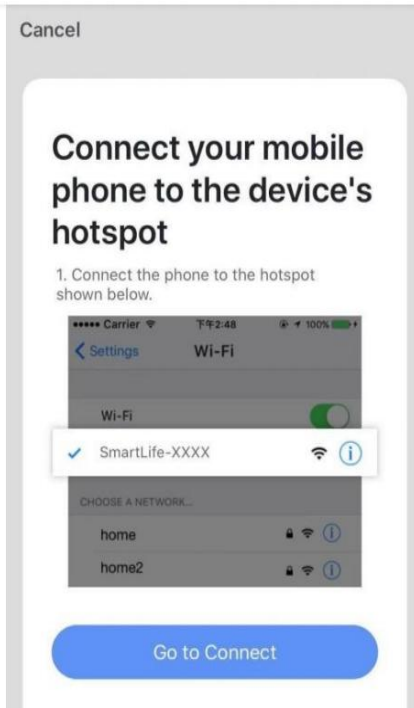
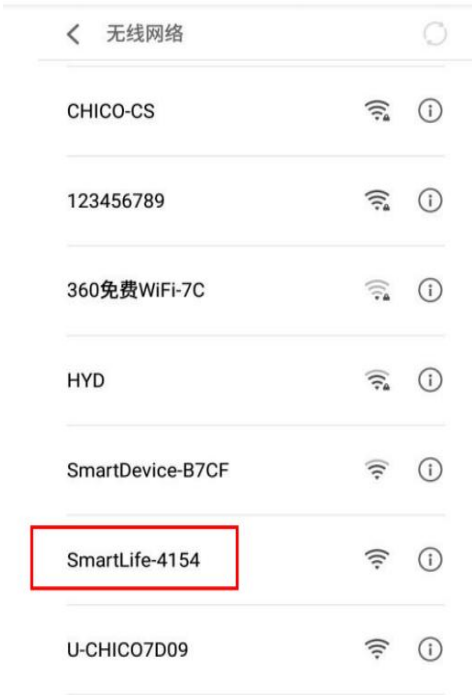

Click Go to connect and jump to the WiFi interface, select WiFi with the words. SmartLife- xxxx

After selecting and connecting, return to the APP interface and enter the network distribution process.

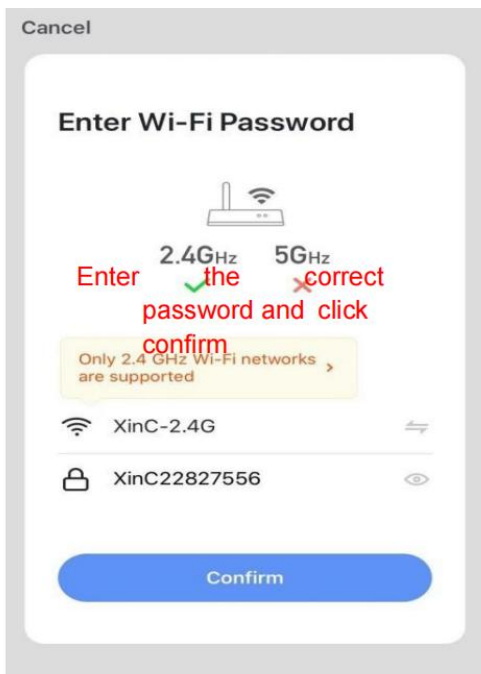

Control introduction

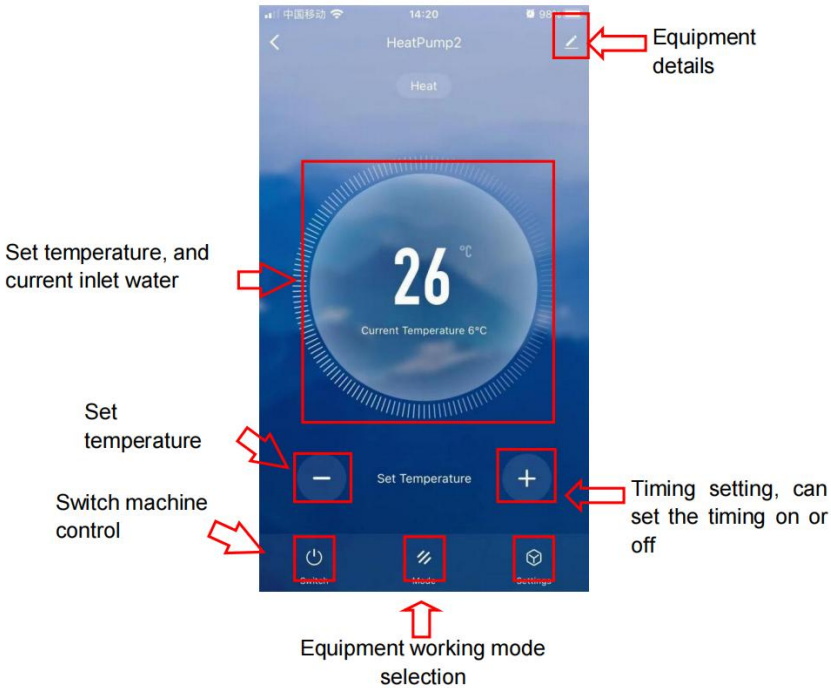
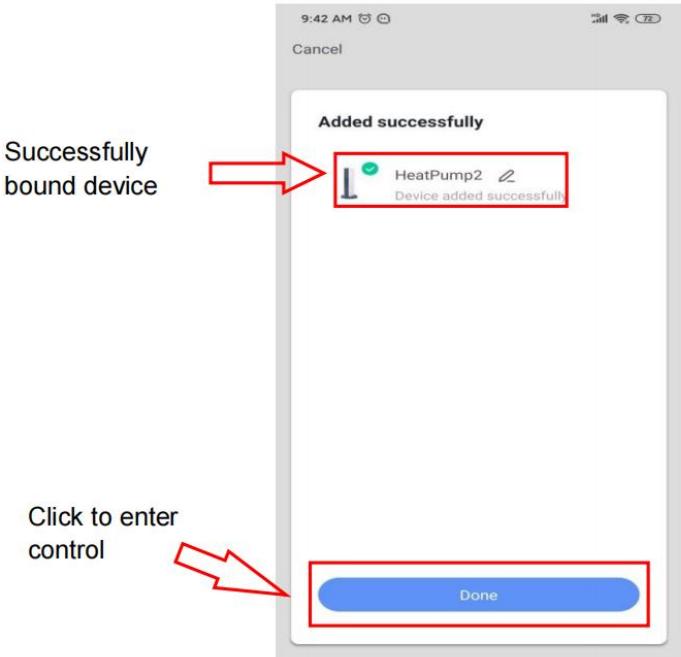

### 9. Error codes

Code	Description	Potential reasons	Solutions
<b>E03</b>	Water flow protection	Insufficient water flow	Check the water circuit system, the opening of by-pass kits, the running of water pump
		Water flow switch disconnected	Check the wiring and reconnect water flow switch
		Water flow switch defective	Change a new one
<b>E04</b>	Antifreeze protection	Ambient/Inlet water temp. is too low and the unit is on standby	The unit will be re-started when the ambient/inlet water temp. goes up.
<b>E05</b>	High pressure protection	Insufficient water flow	Check the water circuit system, the opening of by-pass kits, the running of water pump
		Ambient/ Water temp. is too high	
		Fan motor speed is abnormal or fan motor has damaged	Check the fan motor
		Excess refrigerant gas	Readjust the refrigerant volume
		High pressure switch disconnected or defective	Reconnect or replace high pressure switch
		Piping system jammed	Check the piping system
<b>E06</b>	Low pressure protection	Bad ventilation	Check the installation circumstance. Clean the evaporator. Check the running situation of fan.
		Low pressure switch disconnected or defective	Reconnect or replace low pressure switch
		Gas leakage (Check the gauge)	Detect the leakage point and make the maintenance
		Fan motor speed is abnormal or fan motor has damaged	Check the fan motor
		EEV blocked or piping system jammed	Check the piping system
<b>E09</b>	Connection failure between PCB and controller	Bad wire connection	Check the wiring
		Defective controller	Change a new controller
		Defective PCB	Change a new PCB
<b>E10</b>	Communication failure between PCB and driver module	Bad wire connection	Check the wiring
		Defective PCB	Change a new PCB
		Defective Driver module	Change a new driver module
<b>E12</b>	Exhaust temp. too high	Insufficient water flow	Check the water circuit system/ water flow switch

		Lack of gas	Check if there is a gas leakage
		Piping system jammed	Check the piping system
		Exhaust piping temp. sensor (Purple connector) defective	Change a new sensor
<b>E15</b>	Inlet water temp. sensor failure	Sensor disconnected or defective	Reconnect or replace sensor
<b>E16</b>	Outer piping temp. sensor failure	Sensor disconnected or defective	Reconnect or replace sensor
<b>E18</b>	Exhaust piping temp. sensor failure	Sensor disconnected or defective	Reconnect or replace sensor
<b>E20</b>	Inverter module abnormal protection		Check the voltage, compressor, fan motor etc...
<b>E21</b>	Ambient temp. sensor failure	Sensor disconnected or defective	Reconnect or replace sensor
<b>E23</b>	Over-cooling protection under cooling mode	Insufficient water flow	Check the water circuit system/ water flow switch
		Outlet water temp. sensor (Red connector) failure	Change a new sensor
<b>E27</b>	Outlet water temp. sensor failure	Sensor disconnected or defective	Reconnect or replace sensor
<b>E29</b>	Suction piping temp. sensor failure	Sensor disconnected or defective	Reconnect or replace sensor
<b>E32</b>	Overheating protection under heating mode	Insufficient water flow	Check the water circuit system/ water flow switch
		Outlet water temp. sensor (Red connector) failure	Change a new sensor
<b>E33</b>	Piping temp. too high protection under cooling mode	Ambient/water temp. is too high under cooling mode	Check the scope of using
		Refrigerant system is abnormal	Check the piping system
<b>E42</b>	Inner piping temp. sensor failure	Sensor disconnected or defective	Reconnect or replace sensor
<b>E46</b>	DC fan motor malfunction	Bad wire connection	Check the wiring of fan motor
		Fan motor defective	Change a new fan motor

## 10.Exploded View

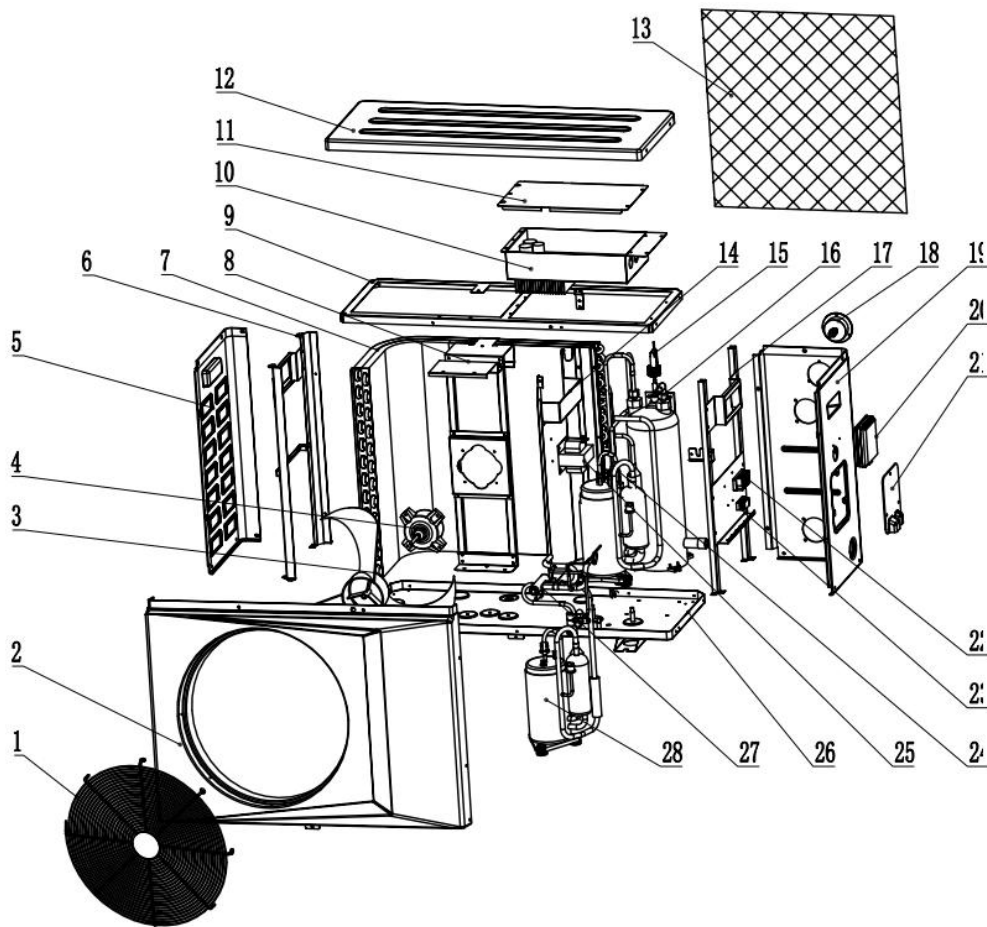

No.	Parts	No.	Parts
1	Ventilation grill	15	Water flow switch
2	Front panel	16	Titanium heat exchanger
3	Fan blade	17	Right structure
4	Fan motor	18	Manometer
5	Left panel	19	Right panel
6	Left structure	20	Control panel
7	Evaporator	21	Electrical terminal cover
8	Fan motor mount	22	Electrical terminal block
9	Upper structure	23	Electric cable support
10	Electric box cover	24	Electronic expansion valve
11	Electric box	25	Reactive resistance
12	Top cover	26	Bottom panel
13	Plastic net	27	4-way valve
14	Middle panel	28	Compressor

# 11.Operation logic

## 11.1 Operation logic

Silent Mode/Powerful Mode

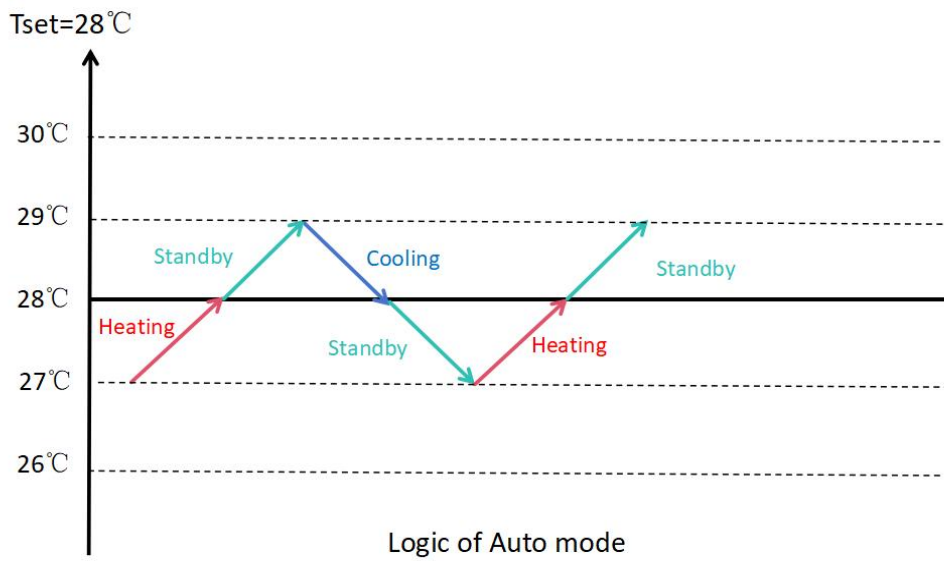
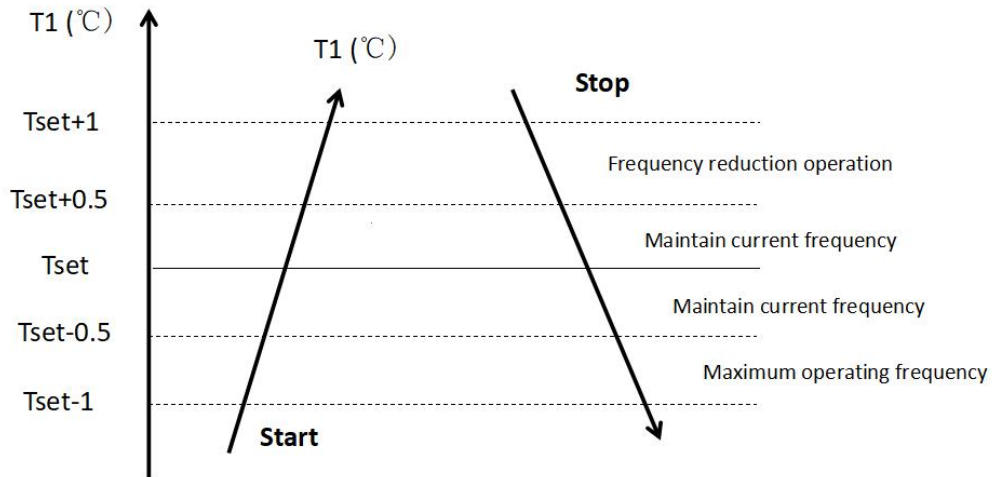



## 11.2 Defrosting logic

11.2.1 While heat pump system will enter into defrosting process, the cooling light  continues to flash.

11.2.2 Enter into defrosting process

No	Ambient temperature	Enter into defrosting process	
		Compressor working time since last defrosting process	Heating coil temperature
1	$\cong 20^{\circ}\text{C} > 4^{\circ}\text{C}$	40 minutes	$-6^{\circ}\text{C}$
2	$\cong 4^{\circ}\text{C} > -3^{\circ}\text{C}$	40 minutes	$-10^{\circ}\text{C}$
3	$\cong -3^{\circ}\text{C}$	100 minutes	Ambient temperature + $(-6^{\circ}\text{C})$ eg: $-3^{\circ}\text{C} + (-6^{\circ}\text{C}) = -9^{\circ}\text{C}$

### 11.2.3 Exist defrosting process

No.	Exist defrosting process
1	Heating coil temperature $\geq 14^{\circ}\text{C}$
2	Heating coil temperature $\geq 8^{\circ}\text{C}$ , and lasting in 90s
3	Defrosting period $> 12$ minutes

Important notice: When your heat pump meets any condition, it will exit defrosting process.

## 12.MAINTENANCE

- a. You should check the water supply system regularly to avoid air entering the system and creation of low water flow, because it would reduce the performance and reliability of HP unit.
- b. Clean your pools and filtration system regularly to avoid the damage of the unit.
- c. Only a qualified technician is authorized to operate the cooling system pressure. You should drain the water from the heat pump if it will stop running for a long time (especially during the winter season or when the ambient temperature drops below 0°C).
- d. Check the water levels before the unit start after a long break in usage.
- e. When the unit is running, there will be condensate water discharging from the bottom of the unit. This is normal.
- f. Action of filling gas must be conducted by professional with R32 operating license.

## 13. Winter Use

**For Full Terms and Conditions please visit -**  
**<http://www.cheshireluxurypools.co.uk/conditions.php>**

### **13. Winter and Summer use of Heat Pumps**

13a. For Winter usage the bottom drain tube and tubing supplied should be removed to prevent a build up of ice causing a blockage and thus the condensate will not be able to escape freely.

13b. If the Heat Pump Unit is to be used over the Winter Season, you **MUST** raise the unit to an adequate and reasonable height from the ground, an absolute minimum of 10cms or 4 inches. This is to accommodate the condensate freely flowing away from the unit, preventing ice build up into the unit and causing any damage. This damage is not covered by the Warranty and will void ALL warranties. Ice and snow build up should be taken into consideration too and must be kept from building up around the unit. This will choke the unit and stop the free exit of condensate amongst other bad effects, which may then affect the electrics of the unit and the fans etc. Necessary steps to protect the unit from this scenario should be taken.

It may be necessary to lift the unit on brackets and wall mount it for instance, so it is out of snow drift or high snow fall. Perhaps to build a shelter to protect the unit.

All warranties will be void if water ingress is found to be the cause of an electrical fault due to negligent usage and that the necessary steps have not been taken to protect the unit for Winter usage by the customer.

13c. For Summer usage the bottom drain tube and tubing supplied should be kept clean and free from debris if used.

13d. Failure to follow these instructions will void warranty for any parts broken or damaged.



