

AI-WIRELESS ROBOTIC POOL CLEANER USER MANUAL

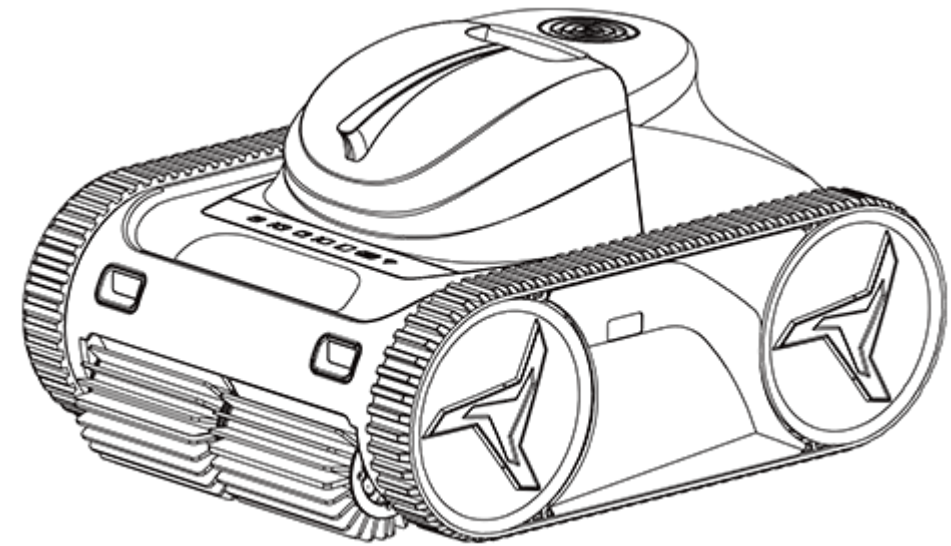

M30/45/60/80

THANK YOU FOR PURCHASING M30/45/60/80 AI-WIRELESS ROBOTIC POOL CLEANER

Please read the manual carefully before
installing or using it and keeping it for subsequent use.

★★ TIPS ★★

How to achieve the most efficient cleaning

Place the robot at the corner of the pool for quick coverage of the entire pool floor area.

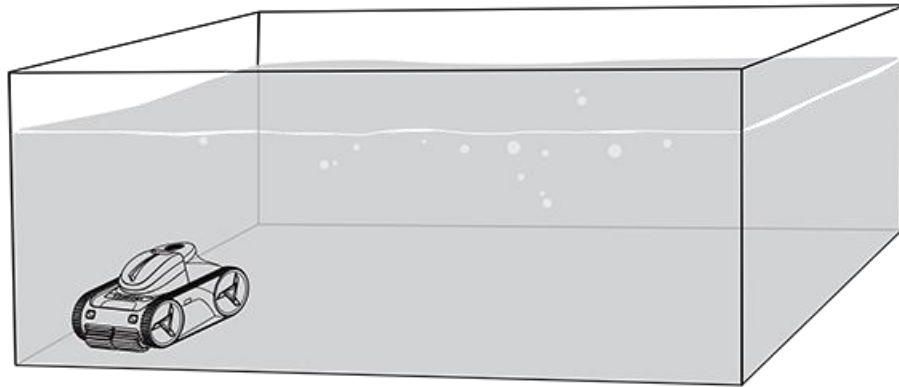

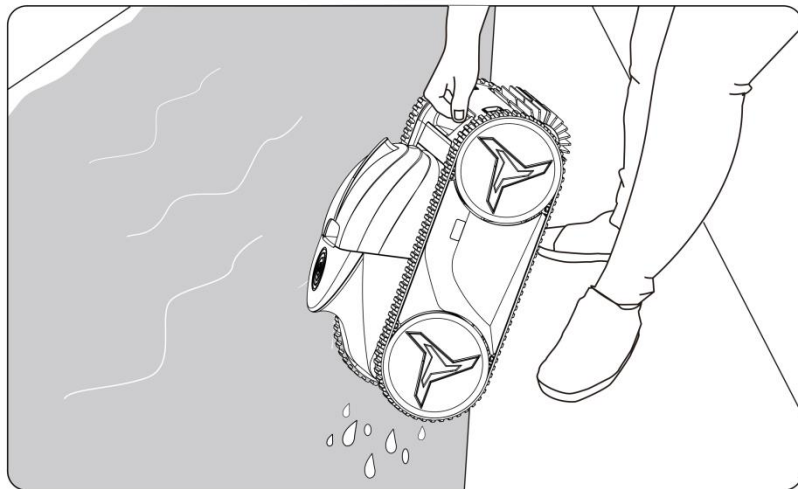

How to drain water from the robot

Place the robot on the edge of the pool for a while and let the water drain out.



Note:

1. Do not use the robot when people or animals are in the pool.
2. Charger **MUST BE DISCONNECTED** before performing any maintenance on the robot.
3. Contact dealer for problems not include in Trouble Shooting Guide.
4. Normally, the robot will stop at the poolside when it encounters any failure or when the battery is less than 15%.
5. If an error occurs, please restart the robot by inserting back the magnetic cap at the bottom of the robot.
6. If the robot is malfunctioning, the error code will appear on the control panel (see 2.1) and the power button  on the control panel flashes red. Pressing the power button  might remove the error warning and allow operation, if error occurs again, please check troubleshooting guide.

Indoor



For switch power supply indoor use only.

Recycling

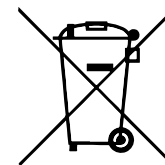

The robot contains a Lithium-ion battery, which should be recycled by qualified battery electronics recyclers. Recycling of batteries and battery-containing products benefits the environment and human health.

 Do NOT disassemble or dispose of the battery in the rubbish or municipal recycling bins.

Warranty Exclusions

Warranty is invalid if any of the following apply:

- Incorrect operation of the unit by not following correct instructions.
- Damage caused to the robot due to misuse or damage caused by any other means than manufacturer defect.
- If robotic pool cleaner is repaired or serviced by an unauthorized dealer or service station.
- If an unauthorized service station damaged battery seal.
- If you overcharge the battery by using a non-specified input power adapter.
- If you cause a fault in the operation of the machine by using non-specified accessories.

not moving	The track is deviated and stuck (Non-failure)	Turn the robot upside down and roll the track forward and backward to restore the track
	Track is damaged	Replace track
	Scrubber gets stuck (Non-failure)	Clean scrubber
	The robot gets stuck by obstacle and shut down for auto-protection (Non-failure)	Remove the obstacle and restart
	Full load of filter basket (Non-failure)	Clean filter basket
Not climbing	Under floor cleaning mode (Non-failure)	Turn to overall cleaning mode
	The impeller is stuck	Check whether there is too much debris in the guide ring, affecting the rotation of the impeller. (Please insert back the magnetic cap before operation, to avoid injuries caused by the impeller rotation)
	Full load of filter basket (Non-failure)	Clean filter basket
	Water inlet is blocked (Non-failure)	Take out of filter basket and clean the water inlet
Poor cleaning capability	Battery low (Non-failure)	Get the robot fully charged
	The impeller is stuck	Remove any debris or hair in the guide ring
	Full load of filter basket (Non-failure)	Clean filter basket
	Water inlet blocked (Non-failure)	Take out of filter basket and clean the water inlet
	Scrubber is damaged	Replace scrubber
	Filter basket is damaged	Replace filter basket
Unusual non-stop	Software failure	Insert the magnetic cap back for 5s, then remove it and restart
Error code	1. Left drive failure 2. Right drive failure 3. Water pump failure 4. Control panel communication failure 5. Infrared sensor failure 6. Water sensor failure	Restart the robot by the magnetic cap to check if the code disappears, if not, please contact the dealers

How to open the filter box

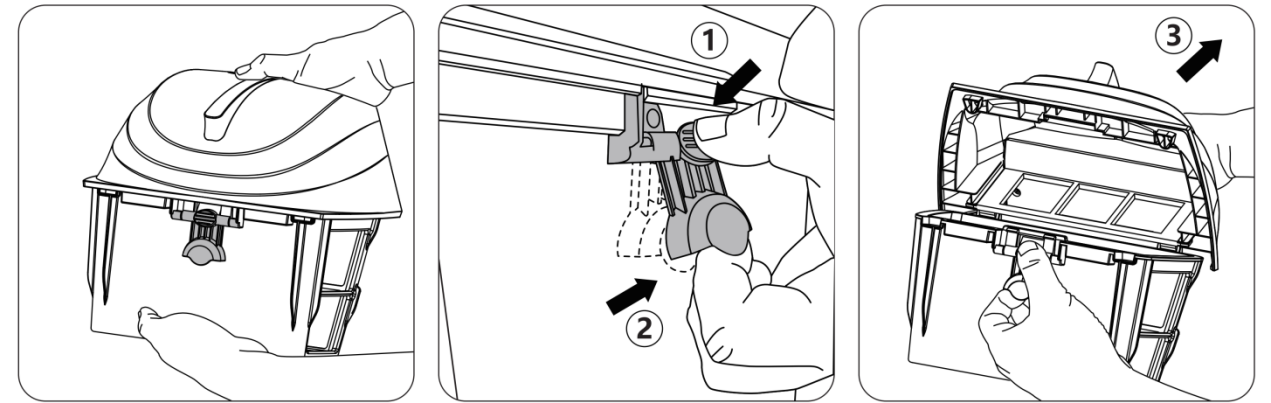

⚠ For battery protection, the robot should be fully charged every 3 months and the magnetic cap should be inserted back if the robot is not used for more than 14 days.

⚠ Do not charge the robot outdoors.

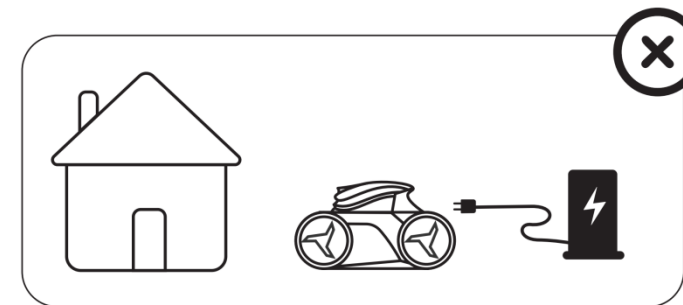

⚠ Do not long-term expose the robot to the sun.

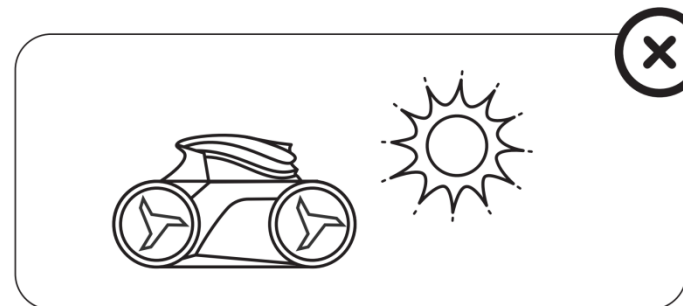

WARNINGS

This page contains information that will help you operate the robot safely, prevent hazards and damage to the robot or other property.

GENERAL WARNINGS

- Read the instructions before operating the robot.
- The robot is designed for pool cleaning; do not use it for other purposes.
- Keep the robot out of reach of children or persons with reduced physical, sensory or mental capabilities without supervision or instruction.
- The robot must be installed, operated and maintained as specified in this manual.
- The robot is to be installed in accordance with manufacturer's guidelines and in compliance with the relevant requirements of the local or national standards for installation. The manufacturer is not responsible for any outcome related to the failure to comply with installation, usage or maintenance guidelines.
- Incorrect installation or use of the robot may cause serious damage to property or injuries to people.
- Do not enter pool while the robot is in water.

WARNINGS ON USE

- Only use the detachable supply unit provided with the robot to recharge the battery. It is suggested to operate the power supply at least 3.5 meters from edge of pool.
- Disconnect the robot from the power supply and insert the magnetic cap back in place before performing any maintenance on the robot.
- Do not operate the robot with wet hands to avoid insensitive touch.
- Do not try to repair the robot yourself or open motor box in case of malfunction, please contact your dealer.
- If there is any malfunction or release of odor from the robot when charging, disconnect it from the power supply immediately and contact your dealer.
- Use only original replacement parts supplied by the manufacturer for service and repair.

GENERAL OPERATION CONDITIONS

Water depth range(m)	Water temperature(°C)	PH	NaCl(PPM)	Chlorine(PPM)
1-2,5	4-35	7,0-7,8	5000 MAX	4 MAX

Note: water temperature below 15°C, the endurance time may be affected.

- The robot is recommended for private pools.
- The robot will automatically stop running if the water depth is less than 40 centimeters for the purpose of motor protection.
- In pool floor mode, the robot will not climb the wall if the slope exceeds 30°.
- Do not use the robot during shock chlorination.
- Do not use the robot in thunderstorm or stormy weather.
- Do not expose the robot to direct rainfall or sunlight for an extended period.

CAUTIONS

- Hold the robot by the pool edge to let the water drain out before lifting from the pool, do it slowly so as to prevent back injury.
- Clean the filter basket after each cleaning cycle.
- Do not lift the robot out of water by track.

REMINDER

- When the robot battery is below 30%, it will only clean the floor of the pool.
- Storing your robot:
 - Ensure the robot is fully dry before storage. This prevents degradation or damage to the motors or internal structure.
 - The filter basket should be cleaned thoroughly after usage and do not leave dirt or debris to dry in filter basket.
 - The charger cable is stored neatly without twists whilst in long-term storage.
- Optimum storage temperature between -10-45°C and storage humidity between 30%-70%/RH.

SECTION 4. TROUBLESHOOTING

Failure	Possible reason	Solution
Charging failure	Debris on the electrode of charging head (Non-failure)	Clean debris
	The bottom Magnetic cap isn't removed (Non-failure)	Remove the Magnetic cap
	The charging kit is damaged	Replace the charging kit
Switching on failure	The Magnetic cap isn't removed (Non-failure)	Remove the Magnetic cap
	Water spots on the robot display or people's hand (Non-failure)	Keep the display and hands dry, then try again
	Wrong operation (Non-failure)	Hold the power button for 3 seconds
	No power in the battery (Non-failure)	Get the robot fully charged
Not working (not moving, not pumping)	Low battery (Non-failure)	Get the robot fully charged
	Out of water (Non-failure)	Make sure the robot under water and the indicator lights are on
	No pressing the on/off button after settings are done(Non-failure)	Press the on/off button after the settings are done, make sure indicator lights are on before putting the robot into water
	Full load of filter basket (Non-failure)	Clean filter basket
Moving but not pumping	The impeller gets stuck	Check whether there is too much debris in the guide ring, affecting the rotation of the impeller. (Please insert back the magnetic cap before operation, to avoid injuries caused by the impeller rotation)
	Full load of filter basket (Non-failure)	Clean filter basket
	Water inlet is blocked(Non-failure)	Take out of filter basket and clean water inlet
	Battery low (Non-failure)	Get the robot fully charged
Pumping but	The moving motor gets stuck	Please contact the dealer for a replacement

Table of Contents

- ① Unfasten the tabs from the holes and remove the brushes.
- ② Fit the side without tabs under the brush holder.
- ③ Roll the brush around its support, slide the tabs into the attachment holes and pull on the end of each tab until its edge passes through the slit.

3.4 Replace the worn tracks

Remove the worn tracks:

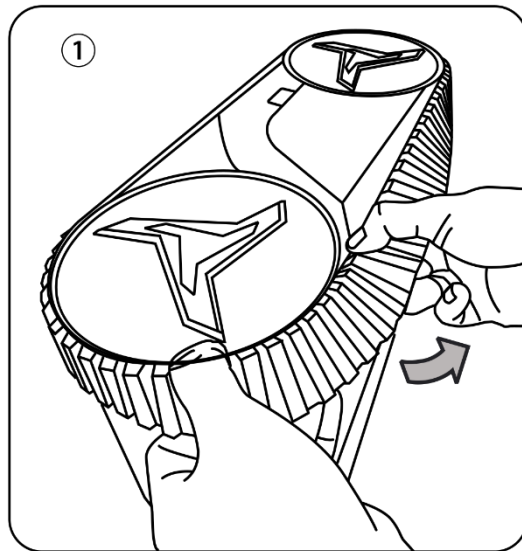

Position the new tracks:

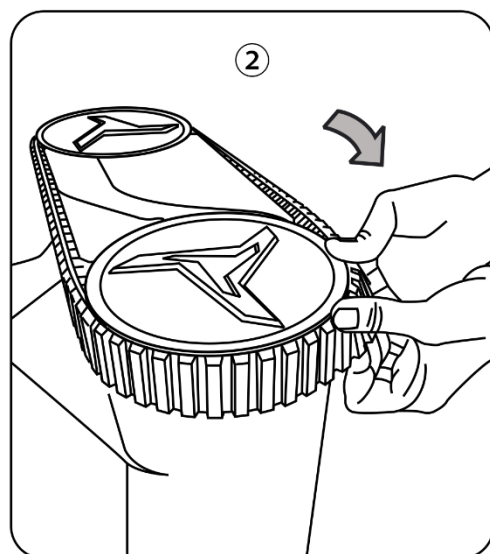
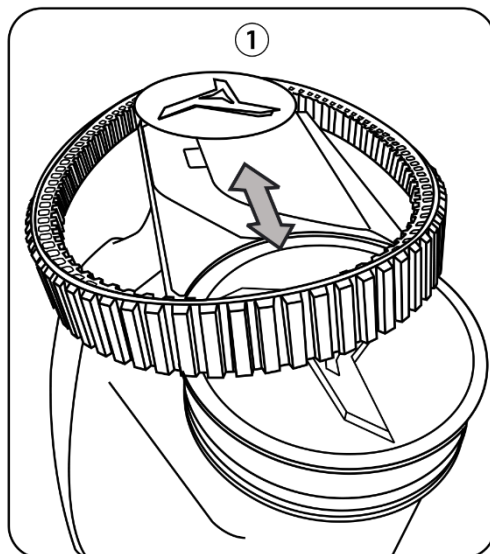

SECTION 1. PRODUCT OVERVIEWS	1
1.1 Packaging content.....	1
1.2 Technical specification.....	2
1.3 Preparation.....	3
SECTION 2. OPERATION	4
2.1 Overview of Control Panel	5
2.2 Operation on the display of the unit	6
2.3 Cleaning the filter basket	7
2.4 Charging the robot.....	7
2.5 WIFI Matching.....	8
SECTION 3. MAINTENANCE.....	9
3.1 Filter maintenance.....	9
3.2 Impeller maintenance.....	9
3.3 Replace the worn brushes	10
3.4 Replace the worn tracks.....	11
SECTION 4. TROUBLESHOOTING	12

SECTION 1. PRODUCT OVERVIEWS

1.1 Packaging content

The following items are included in the packaging of robot. Please contact your dealer if any damage or loss.

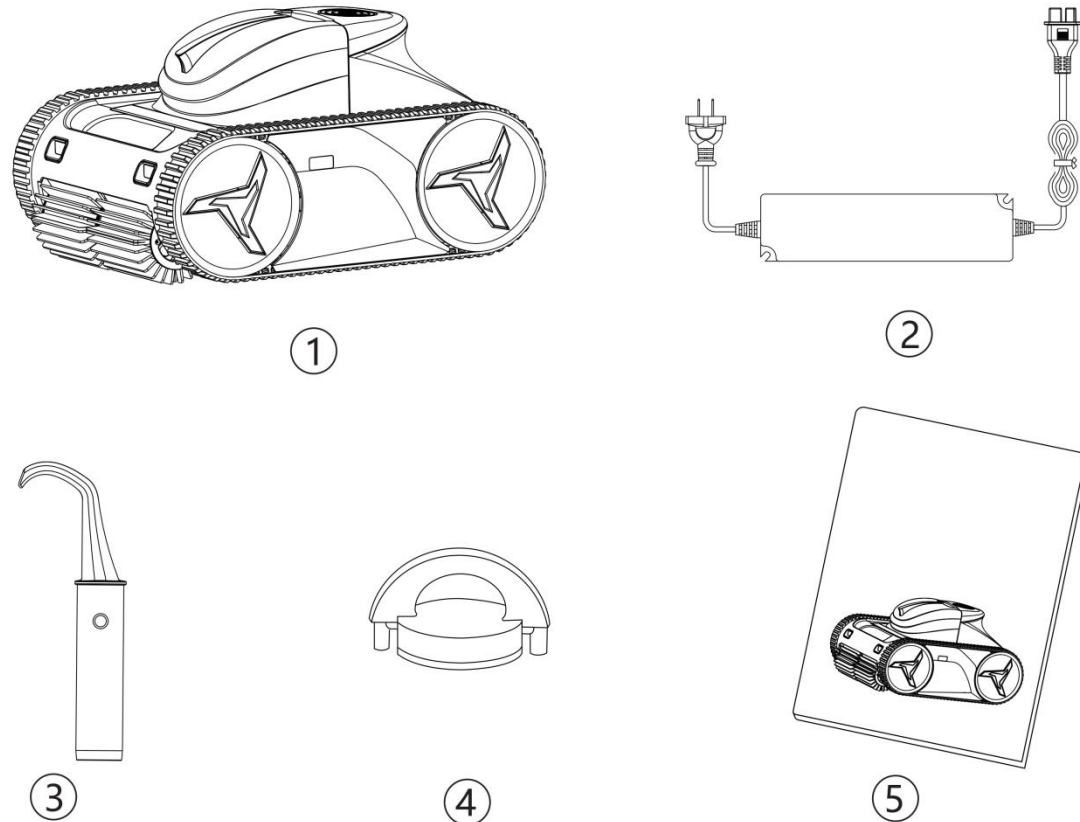

① The robot ② Charger ③ Hook ④ Magnetic cap*2 ⑤ User manual

Note:

1. Remove the Magnetic cap ④ when using or charging. Insert Magnetic cap back to machine's bottom for battery protection if not using the robot for more than 14 days.
2. If the robot fails, insert the Magnetic cap ④ back for 2 seconds, remove the magnetic cap ④ and restart the robot.

Follow the below steps:

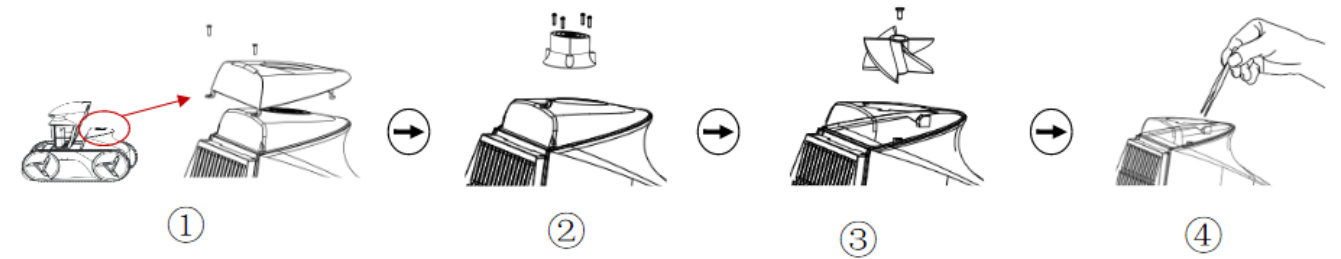

- ① Take out the filter box, remove the fixing screws of the inflow ring cover, and take out the inflow ring cover.
- ② Remove the deflector fixing screws and take out the deflector.
- ③ Remove the impeller screw and take out the impeller. Note: Wear gloves when removing the impeller to prevent injury from sharp edges.
- ④ Clean the impeller debris and reassemble all the parts mentioned above in order.

Note: If you have any difficulty with impeller maintenance, contact the dealer for assistance.

3.3 Replace the worn brushes

Remove the worn brushes & position the new brushes:

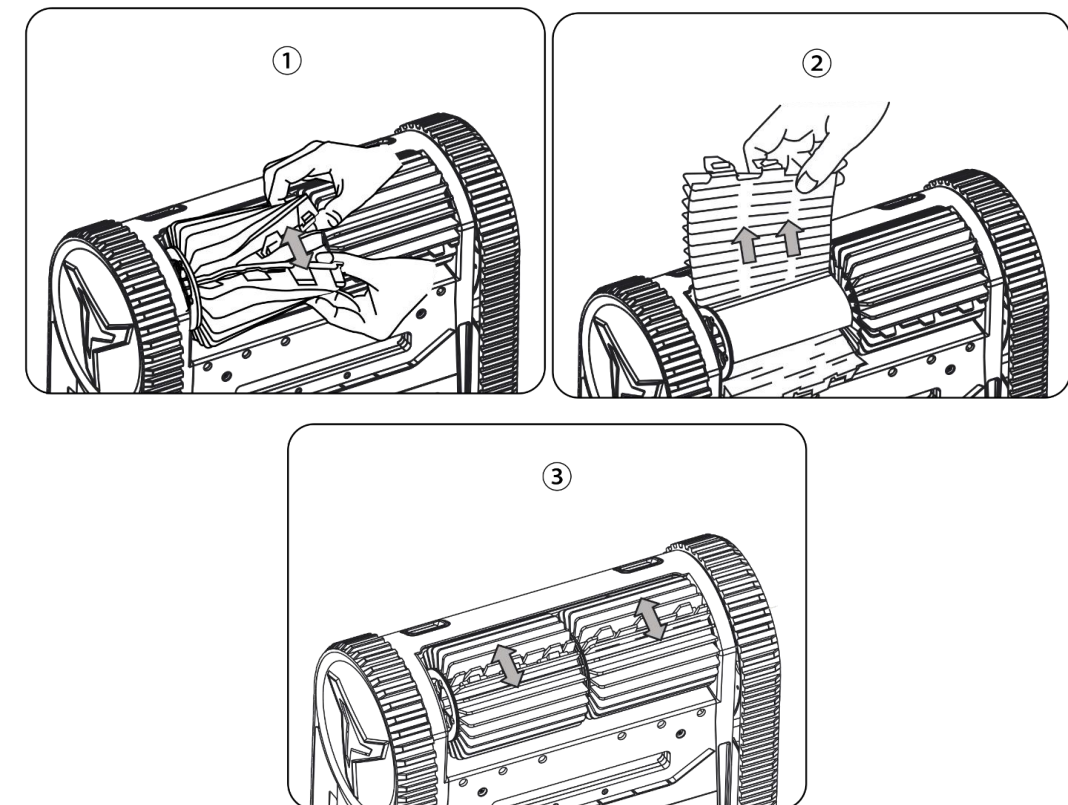

SECTION 3. MAINTENANCE

⚠ WARNING

1. To avoid electric shock and other hazards which could result in major injuries, disconnect the adapter from the power source before performing any cleaning and maintenance.
2. Before any maintenance, insert the magnetic cap back to avoid injuries caused by impeller rotation.

3.1 Filter maintenance

1. Clean the filter thoroughly and regularly for better cleaning and climbing performance. Otherwise, the cleaning and climbing performance may be affected when the filter is full or clogged.
2. Annually clean the clogged filter with mild acidic detergent, suitable safety equipment must be worn when during the process.

3.2 Impeller maintenance

Visually check whether the impeller or impeller shaft is entangled with hair or other debris when the robot has a reduced suction or climbing performance, clean the debris trapped in the impeller.

***The magnetic cap MUST be inserted back before any maintenance on the impeller.**

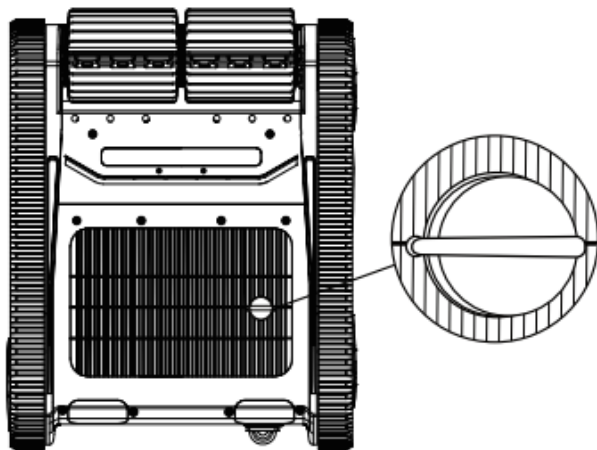

1.2 Technical specification

Model	M80	M60	M45	M30
Endurance condition reference*: Floor mode				
Endurance time	8,0h	6,0h	4,5h	3,0h
Endurance condition reference*: Floor/wall/waterline mode				
Endurance time	4,5h	3,5h	2,5h	2,0h
Charging time	8,0h	6,0h	4,5h	3,0h
Battery	14,0Ah (352wh)	10,4Ah (262wh)	7,8Ah (196wh)	5,2Ah (131wh)
Optimum pool temperature	4~35°C			
Cleaning mode	Floor only; Floor/Wall/Waterline			
Multiple cycle option	0,5h/1,0h/2,0h/Full Run			
AI Timer	Clean every 24h/48h/72h			
App application	YES			
Filter capacity	3,2L			
Filtration accuracy	100µm			
Pump flow rate	22-15(m³/h)	20-15(m³/h)		
Running power	30-110W			
Moving speed	12m/min			
Number of motors	3			
Charger input	100-240VAC ~ 50/60Hz			
Running voltage/current	25,2V/1,2A			
Charger power	72,5W			
Robot NW/GW	12,0 / 17,0kg	12,0 / 17,0kg	11,5 / 16,5kg	11,5 / 16,5kg
Robot dimension (L*W*H)	495*395*265 mm			
Robot packaging dimension (L*W*H)	580*448*330 mm			

* Reference: Above working time is based on 2 hours' cleaning each time at floor mode in the liner pool.

Note: The manufacturer reserves the right to modify these specifications without notice.

1.3 Preparation

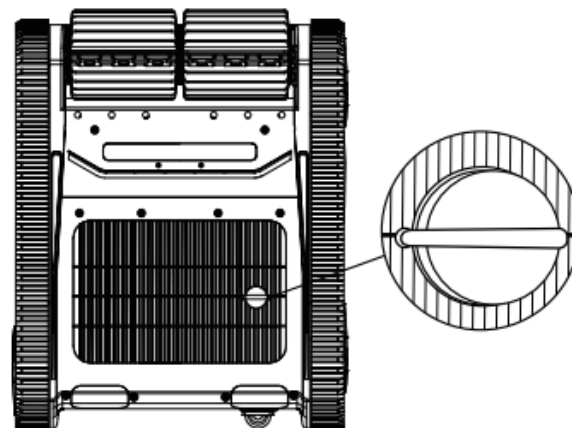
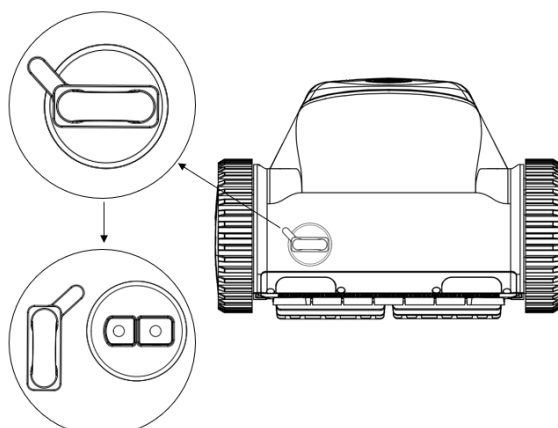
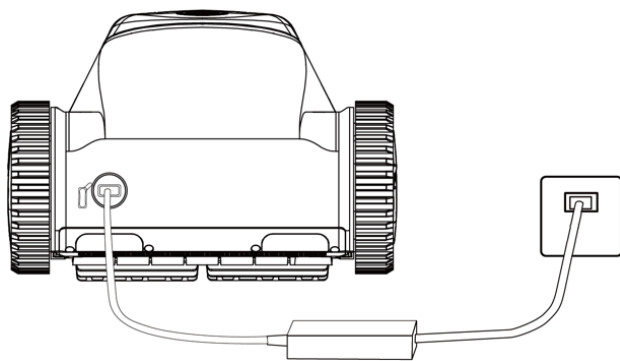
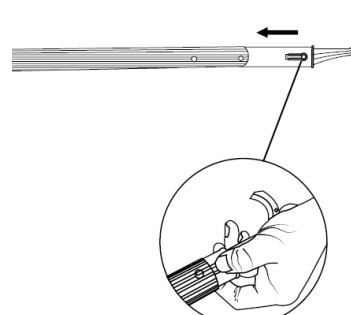

<p>① Remove the Magnetic cap from the bottom of the robot and store it well.</p> 	<p>② Remove the plug cover. When fully charged, cover the plug again.</p> 
<p>③ Connect to the power(100-240V) supply using the charger supplied.</p> <p>Battery 3 bars green lights on: Battery level: 100%</p> <p>Fully charge the robot before the first use.</p> <p>*Suggested Charging Temperature: 6-35°C.</p> 	<p>④ Install the configured hook on the rod (Rod is exclusive).</p> 

Note: Use the original power adaptor with the robot ONLY.

2.5 WIFI Matching

***Attention:**

1. Turn on Bluetooth & Wifi before APP connection.
2. Make sure the Wifi network connected is 2.4GHz and in a good signal.
3. Allow APP access to Bluetooth.
4. Make sure  is flashing during APP connection.

Hold  for 3s, then the robot will have a beep sound, the robot enters matching mode,  start flashing, open the "AI-BOT" APP to search device and match the robot to your network and go matching, the robot will beep three times and  will turn green after network is matched.

Setup of the robot can be operated via the APP through Wifi or Bluetooth.

Setup of the robot cannot be operated by APP if the robot is in the pool. (Due to the physical limitation of radio signal penetration in water).

Note: download the "AI-BOT" APP in iOS App Store/ Google Play Store.



2.3 Cleaning the filter basket

After a cleaning cycle, the robot will self-park at the pool side. Use the hook to catch the handle and lift the robot out of the water, drain the water from the robot and clean the filter basket as shown below:

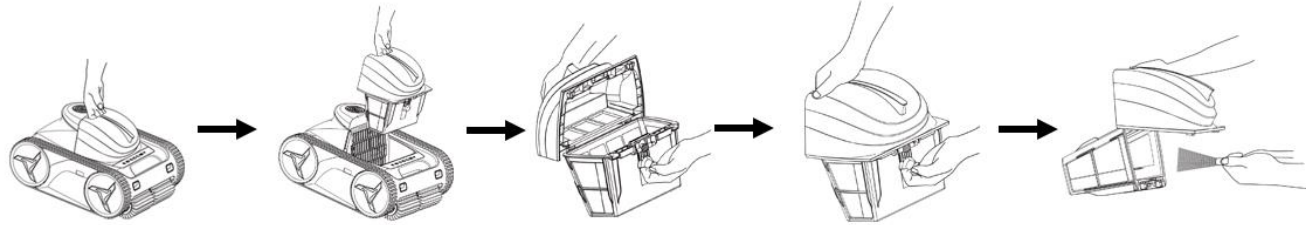

Note:

To prevent injury, wear rubber gloves when cleaning the filter basket.

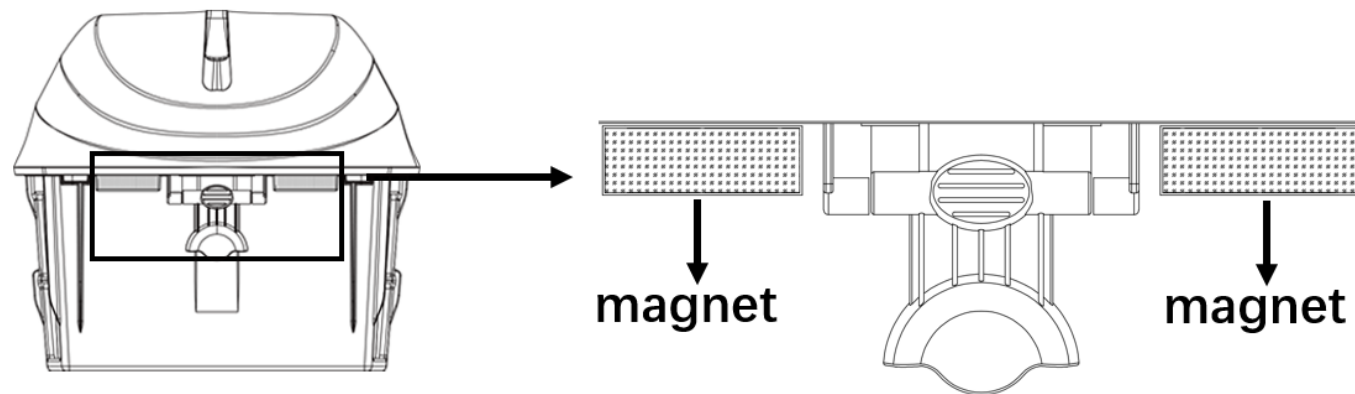

2.4 Charging the robot

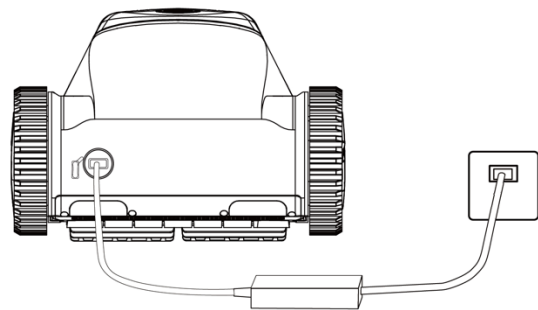

1. Plug the adapter into power supply and make sure that indicator light is being green.
2. Open the cover of the robot's plug to plug the adapter.
3. If the battery 3 bars green lights are on, the robot is fully charged.
4. Before charging, make sure charging port is dry.
5. Disconnect the charger after charging to protect the battery.
6. Charging plug should be inserted before robot use.
7. If the robot needs to be stored for long time, it should be fully charged at least every three months to protect.

SECTION 2. OPERATION

⚠ CAUTION

To prevent possible damage to the robot or people, be sure to follow these guidelines:

- After cleaning is completed, place the robot in a cool dry place away from direct sunlight.
- Take care when moving robot from pool and allow water to drain from robot before lifting.

IMPORTANT

- Once the robot is set up, drop into the water within 3 minutes or the robot will enter sleep mode.
- Clean the filter basket after the cleaning cycle. Avoid cleaning the surface of the filter box directly with your hands.
- The robot has a safety feature that automatically stops if not run in a pool with water.
- Turn the robot in all directions to release any air trapped in the robot before it enters the water. Shown below.

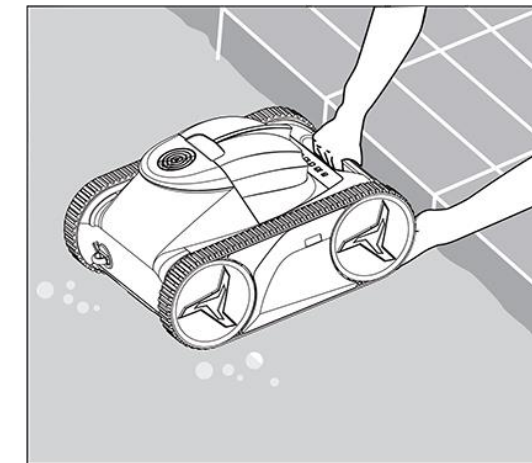

2.1 Overview of Control Panel

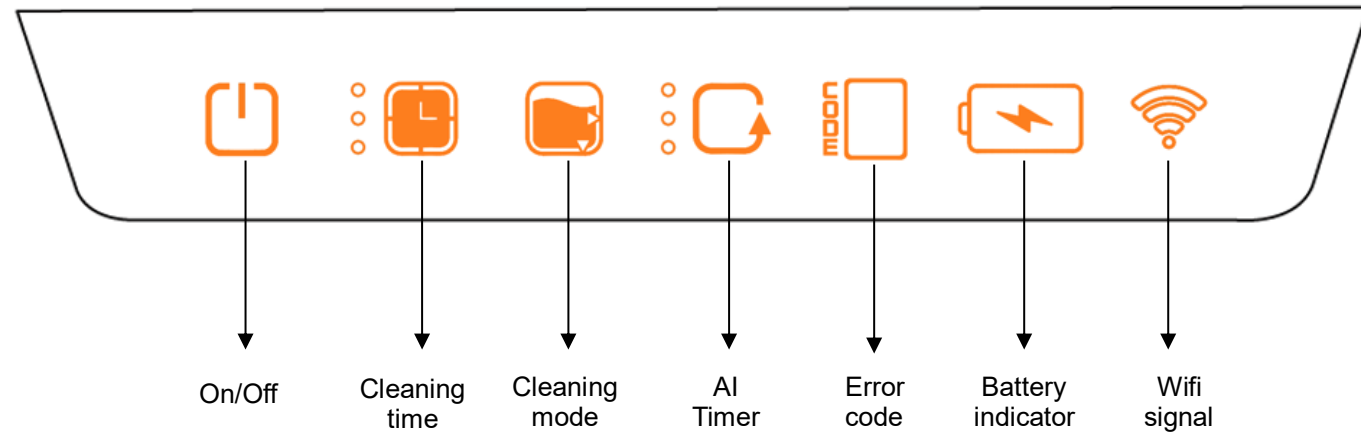

Type of button	Icon	Display Status	Description
Power switch		Green light flashes	Setup status
		Green light being on	Running status/Inspection status under water
Cleaning time		1 green light being on	Cleaning time: 0.5H
		2 green lights being on	Cleaning time: 1.0H
		3 green lights being on	Cleaning time: 2.0H
		All lights being off	Cleaning until low battery
Cleaning mode		Triangle green light at the bottom being on	Floor cleaning mode
		Both triangle green lights being on	Overall cleaning mode (Floor, wall, waterline)
AI Timer		1 green light being on	Cleaning every 24 hours
		2 green lights being on	Cleaning every 48 hours
		3 green lights being on	Cleaning every 72 hours
		All lights being off	Do not need AI Timer
Error code		1	Left drive failure
		2	Right drive failure
		3	Water pump failure
		4	Control panel communication failure

		5	Infrared sensor failure
		6	Water sensor failure
Battery light (Non-charging status)		1 green light being on	Battery level: 20-50%
		2 green lights being on	Battery level: 50-75%
		3 green lights being on	Battery level: 75-100%
Low battery		1 red light flashes	Battery level: 15-20%
Battery light (Charging status)		1 green light flashes	Battery level: 0-50%
		1 green light being on, 1 green light flashes	Battery level: 50-75%
		2 green lights being on, 1 green light flashes	Battery level: 75-100%
		3 green lights being on	Battery level: 100%
Wifi signal		Green light flashes	Network matching
		Green light on	Network matched
		Red light flashes	Failure connection

2.2 Operation on the display of the unit

- Hold for 3 seconds to activate the robot. When flashes, start robot set up. After setup, press again as confirmation. Once completed, put the robot into the water. The robot will start cleaning automatically when it touches the floor. If there is no operation on the robot within 3 minutes from flashes, the robot will shut down and enter sleep mode.

*Note: There are two different outcomes when setting up the AI Timer:

(Take set of "Cleaning every 24 hours" in AI Timer for example)

- Press once and put the robot into the water. The robot will start immediately. After one clean cycle, the robot will enter sleep mode and automatically wake up after 24 hours.
- Press for 3s and then put the robot into the water. The robot will enter sleep mode. After 24 hours, the robot will automatically wake up and start cleaning.

- If the battery is less than 15% during the cleaning cycle, will keep flashing a red light, the robot will self-park at the pool side. It will enter sleep mode after 5 minutes.